

PROJECT DATA:
 SITE ADDRESS: 7002 78th AVE. SE. MERCER ISLAND, WA 98040
 ZONE: R-15
 LEGAL DESCRIPTION:
 POR OF GL 2-BEG AT PT 2314.98 FT W & 520.93 FT N OF E 1/4 COR OF SEC TH S 88-48-22 E 458 FT TO TPOB TH N 01-26-23 E 130 FT TO S MGN OF SE 70TH ST TH N 88-48-22 W 115.39 FT TH S 01-26-23 W 130 FT TH S 88-48-22 E 115.39 FT TO TPOB
 LOT AREA: 15,001 SQ.FT.

| NO. | DATE | REVISIONS |
|-----|------|-----------|
| | | |
| | | |
| | | |
| | | |

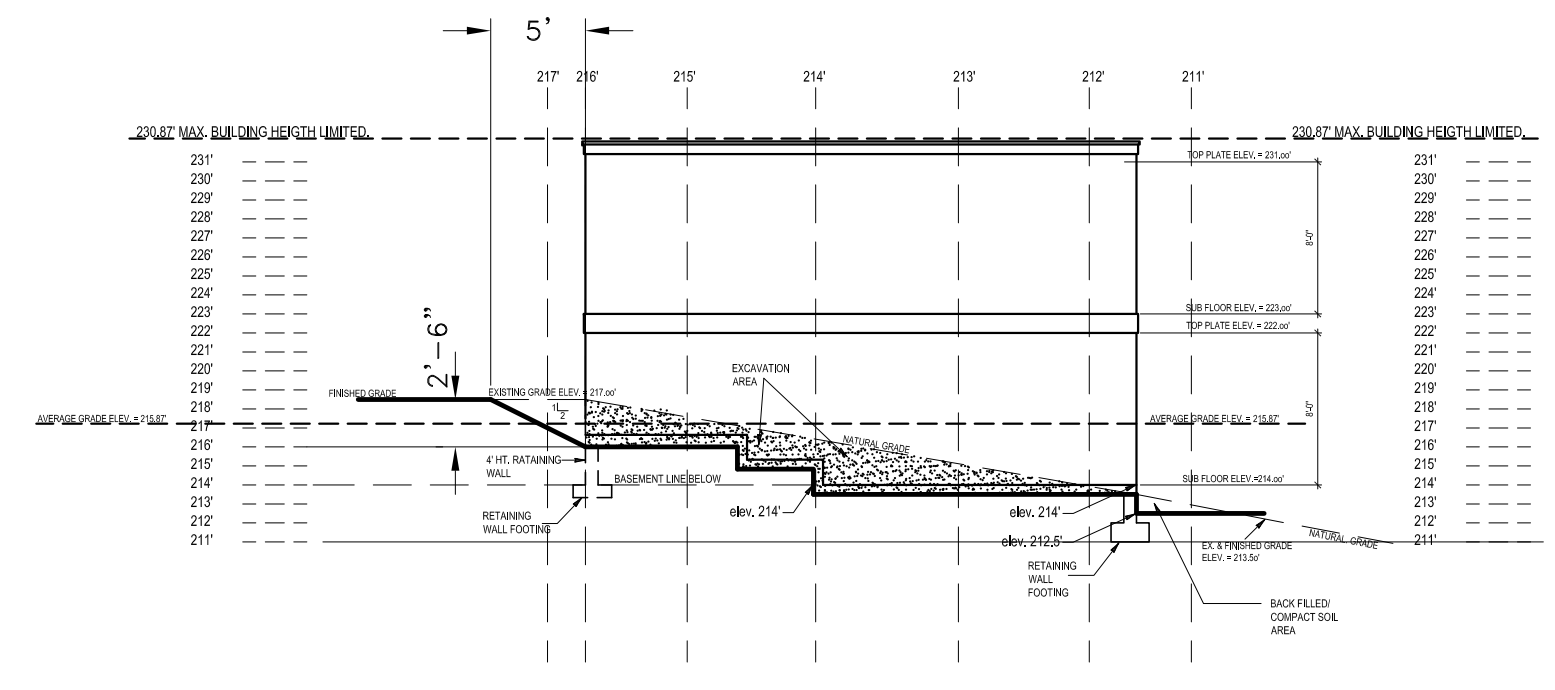
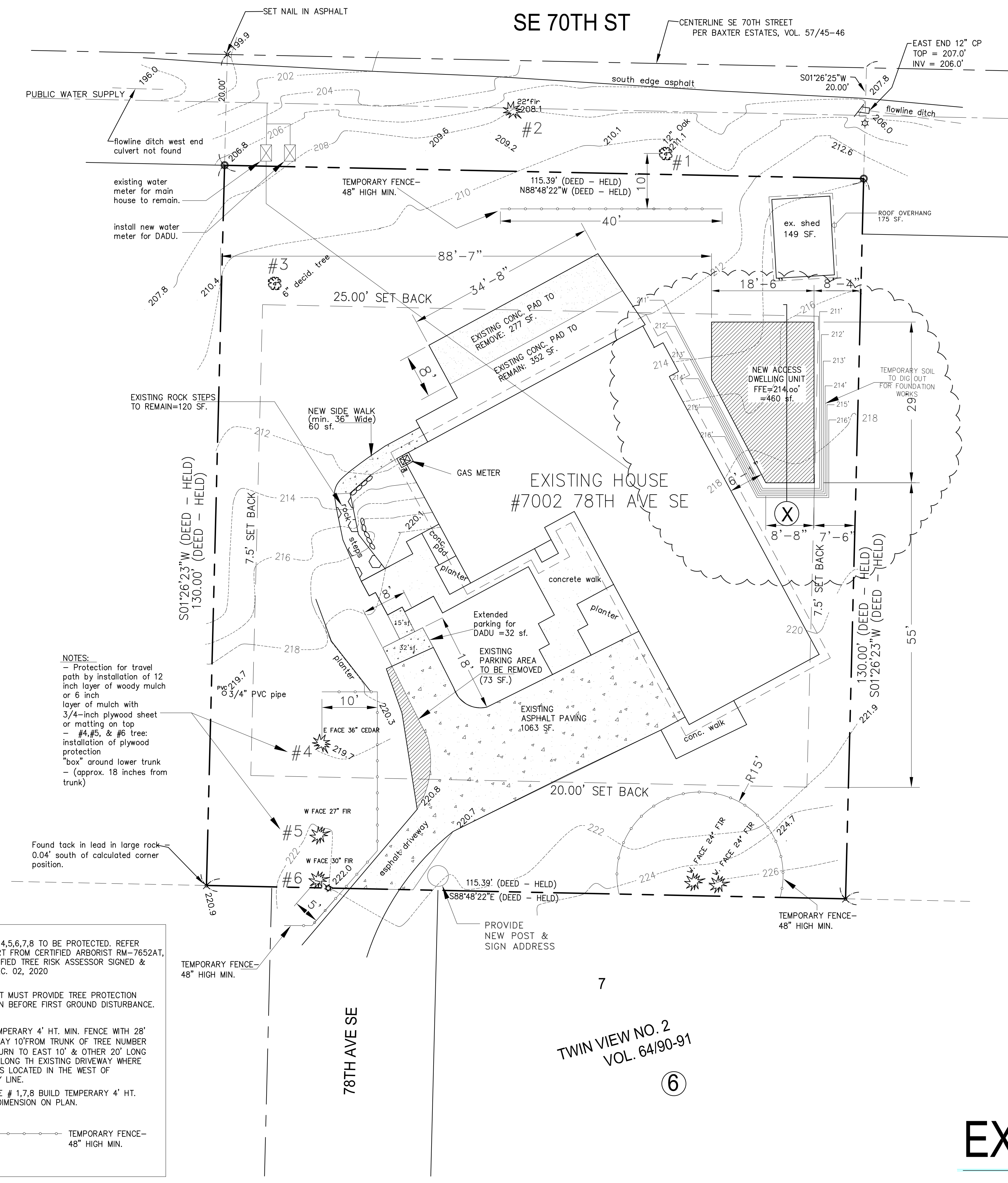

NOTES:
 - Protection for travel path by installation of 12 inch layer of woody mulch or 6 inch layer of mulch with 3/4-inch plywood sheet or matting on top
 - #4, #5, & #6 tree: installation of plywood protection "box" around lower trunk - (approx. 18 inches from trunk)

NOTE:
 TREE # 1,4,5,6,7,8 TO BE PROTECTED. REFER TO REPORT FROM CERTIFIED ARBORIST RM-7652AT, ISA QUALIFIED TREE RISK ASSESSOR SIGNED & DATED DEC. 02, 2020

APPLICANT MUST PROVIDE TREE PROTECTION AREA SIGN BEFORE FIRST GROUND DISTURBANCE.

BUILD TEMPORARY 4' HT. MIN. FENCE WITH 28' LONG, AWAY 10' FROM TRUNK OF TREE NUMBER 4 & 5, TURN TO EAST 10' & OTHER 20' LONG FENCE ALONG TH EXISTING DRIVEWAY WHERE THE TREES LOCATED IN THE WEST OF PROPERTY LINE.

WITH TREE # 1,7,8 BUILD TEMPORARY 4' HT. MIN. AS DIMENSION ON PLAN.

TEMPORARY FENCE- 48" HIGH MIN.

PREPARED BY:
**YOU CHUNG RESIDENCE/ADU
 NEW CONSTRUCTION**
 7002 78th AVE. SE, MERCER ISLAND 98040
 PARCEL NUMBER: 252404-9217

PREPARED BY:
T & L HOME DESIGN
 Architectural - Design
 PHONE: 253-441-1651
 1721 E. 68th ST.
 TACOMA, WA, 98404
 Email: tncd@tlhomedesign.com

| | |
|-----------|----------------|
| BY: | T.N. |
| DATE: | 7/29/20 |
| CHECKED: | T.N. |
| SHEET NO. | A0.0 |
| JOB NO. | TL20-12 |

EXCAVATION PLAN

SCALE 1" = 10'

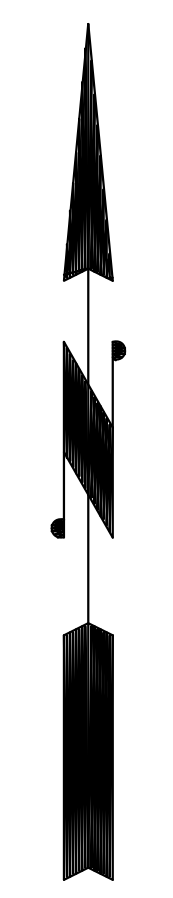

TWIN VIEW NO. 2
 VOL. 64/90-91

6

GENERAL NOTES:

CODES:

DESIGN IS IN ACCORDANCE WITH THE 2015 INTERNATIONAL RESIDENTIAL CODE (IRC) AS AMENDED BY THE LOCAL BUILDING DEPARTMENT.

LIVE LOADS:

ROOF.....29 PSF (SNOW, 4 PSF FOR SOLAR READY)
FLOOR.....40 PSF
DECKS.....60 PSF
LATERAL.....WIND.....EXPOSURE C- 110 MPH
SEISMIC.....PER ZONE D

SITE WORK:

UNLESS A SOILS INVESTIGATION REPORT BY A LICENSED SOILS ENGINEER IS PROVIDED THE FOUNDATION DESIGN IS BASED UPON AN ASSUMED AVERAGE SOIL BEARING CAPACITY OF 1500 PSF. EXTERIOR FOOTING SHALL BEAR 18" MINIMUM BELOW FINISHED GRADE UNLESS NOTED OTHERWISE. ALL FOOTINGS TO BEAR ON FIRM, UNDISTURBED EARTH BELOW ORGANIC SURFACE SOIL. ALL BACK FILL MATERIAL SHALL BE THOROUGHLY COMPACTED. FOUNDATION VENTS SHALL NOT INTERFERE WITH OUTSIDE SOIL, AND DIRECT LOAD PATH OF COLUMNS ABOVE.

CONCRETE:

REFER TO STRUCTURAL NOTES.

INSULATION AND MOISTURE PROTECTION:

UNLESS NOTED OTHERWISE, INSULATION SHALL CONFORM TO THE WASHINGTON STATE ENERGY CODES. INSULATION BAFFLES TO MAINTAIN 1½ INCH CLEAR SPACE ABOVE INSULATION. BAFFLES TO EXTEND 6-INCHES ABOVE BATT INSULATION. BAFFLES TO EXTEND 12-INCHES ABOVE LOOSE FILL INSULATION. INSULATE BEHIND BATHTUBS, SHOWERS, PARTITIONS AND CORNERS FACE STAPLE BATT. FRICTION FIT FACED BATT. USE 4 MIL (0.004") POLYETHYLENE VAPOR BARRIER AT WALLS. USE PVA PAINT WITH A DRY CUP PERM RATING OF OR (MAX) R-10 INSULATION UNDER ELECTRIC WATER HEATERS.

1. EXTERIOR JOINTS AROUND WINDOWS AND DOOR FRAMES, OPENINGS BETWEEN WALLS AND FOUNDATIONS, BETWEEN WALLS AND ROOF AND BETWEEN WALL PANELS, OPENINGS AT PENETRATION OF UTILITY SERVICE THROUGH WALLS, FLOORS, AND ROOF, AND ALL OTHER SUCH OPENINGS IN THE BUILDING ENVELOPE, INCLUDING ACCESS PANELS INTO UNHEATED SPACES, SHALL BE SEALED, CALKED, GASKETED OR WEATHER-STRIPPED TO LIMIT AIR INFILTRATION.

2. ALL EXTERIOR DOORS, OTHER THAN FIRE-RATED DOORS, SHALL BE DESIGNED TO LIMIT AIR INFILTRATION AROUND THEIR PERIMETER WHEN IN A CLOSED POSITION. DOORS BETWEEN RESIDENCE AND GARAGE ARE NOT CONSIDERED "FIRE-RATED" AND MUST MEET THE ABOVE REQUIREMENT.

R-10 INSULATION AT ALL HEADERS, BEAMS ABOVE OPENINGS.

ALL WINDOW, AND DOOR HEADERS SHALL BE INSULATED WITH A MINIMUM OF R-10 INSULATION

VAPOR BARRIERS / GROUND COVERS:

AN APPROVED VAPOR BARRIER SHALL BE PROPERLY INSTALLED IN FLOOR DECKS, IN ENCLOSED RAFTER SPACES FORMED WHERE CEILINGS ARE APPLIED DIRECTLY TO THE UNDERSIDE OF ROOF RAFTERS, AND AT EXTERIOR WALLS IN INSTALLED BATT WITH A PERM RATING LESS THAN ONE MAY BE INSTALLED IF THE VAPOR BARRIER IS TO THE WARM SIDE, STAPLES SHALL BE PLACED NOT MORE THAN 8-INCHES AND GAPS BETWEEN THE FACING AND THE FRAMING SHALL NOT EXCEED

A GROUND COVER OF 6 MIL (0.006") BLACK POLYETHYLENE OF EQUIVALENT SHALL BE LAID OVER THE GROUND IN ALL CRAWL SPACES. THE GROUND COVER SHALL BE OVERLAPPED ONE FOOT AT EACH JOINT AND SHALL EXTEND TO THE FOUNDATION WALL.

THE NET FREE VENTILATION AREA FOR ATTIC VENTILATION MAY BE ½% OF THE AREA OF THE VENTILATED SPACE PROVIDED THAT A VAPOR BARRIER HAVE A PERM RATING NOT EXCEEDING ONE IN INSTALLED ON THE WARM SIDE OF THE INSULATION.

LANDINGS AT DOORS

R311.3 FLOORS AND LANDINGS AT EXTERIOR DOORS. THERE SHALL BE A LANDING OR FLOOR ON EACH SIDE OF EACH EXTERIOR DOOR. THE WIDTH OF EACH LANDING SHALL BE NOT LESS THAN THE DOOR SERVED, EVERY LANDING SHALL HAVE A DIMENSION OF NOT LESS THAN 36 INCHES MEASURED IN THE DIRECTION OF TRAVEL. THE SLOPE AT EXTERIOR LANDINGS SHALL NOT EXCEED 1 UNIT VERTICAL IN 12 UNIT HORIZONTAL (2 PERCENT).

R311.7 STAIRWAYS:

REFER TO STAIR DETAIL ON SHEET A3

R311.7.8 HANDRAILS:

HANDRAILS SHALL BE PROVIDED ON NOT LESS THAN ONE SIDE OF EACH CONTINUOUS RUN OF TREADS OR FLIGHT WITH FOUR OR MORE RISERS.

R311.7.8.1 HANDRAIL HEIGHT MEASURED VERTICALLY FROM THE SLOPED PLANE ADJOINING THE TREAD NOSING, OR FINISH SURFACE OF RAMP SLOPE, SHALL BE NOT LESS THAN 34 INCHES AND NOT MORE THAN 38 INCHES.

R311.7.8.2 CONTINUITY. HANDRAILS FOR STAIRWAYS SHALL BE CONTINUOUS FOR THE FULL LENGTH OF THE FLIGHT, FROM A POINT DIRECTLY ABOVE THE TOP RISER OF THE FLIGHT TO A POINT DIRECTLY ABOVE THE LOWEST RISER OF THE FLIGHT. HANDRAIL ENDS SHALL BE RETURNED OR SHALL TERMINATE IN NEWEL POSTS OR SAFETY TERMINALS. HANDRAILS ADJACENT TO A WALL SHALL HAVE A SPACE OF NOT LESS THAN 1 ½ INCHES BETWEEN THE WALL AND THE HANDRAILS.

REFER TO STAIR DETAIL ON SHEET A3 FOR MORE INFORMATION.

R312.1 GUARDS FALL PROTECTION

R312.1.1 WHERE REQUIRED, GUARDS SHALL BE LOCATED ALONG OPEN SIDED WALKING SURFACES, INCLUDING STAIRS, RAMPS, AND LANDINGS, THAT ARE LOCATED MORE THAN 30 INCHES MEASURED VERTICALLY TO THE FLOOR OR GRADE BELOW AT ANY POINT WITHIN 36 INCHES HORIZONTALLY TO THE EDGE OF THE OPENING SIDE. INSECT SCREENING SHALL NOT BE CONSIDERED AS A GUARD.

R312.1.2 HEIGHT. REQUIRED GUARDS AT OPEN SIDED WALKING SURFACES, INCLUDING STAIRS, PORCHES, BALCONIES, OR LANDINGS, SHALL BE NOT LESS THAN 36 INCHES IN HEIGHT AS MEASURED VERTICALLY ABOVE THE ADJACENT WALKING SURFACE OR THE LINE CONNECTING THE LANDING EDGES OF THE TREADS.

R312.2 WINDOW FALL PROTECTION

R312.2.1 WINDOW SILLS. IN DWELLING UNITS, WHERE THE TOP OF THE SILL OF AN OPERABLE WINDOW OPENING IS LOCATED LESS THAN 24 INCHES ABOVE THE FINISHED FLOOR AND GREATER THAN 72 INCHES ABOVE THE FINISHED GRADE OR OTHER SURFACE BELOW ON THE EXTERIOR OF THE BUILDING, THE OPERABLE WINDOW SHALL COMPLY WITH ONE OF THE FOLLOWING:
1. OPERABLE WINDOWS WITH OPENINGS THAT WILL NOT ALLOW A 4 INCHES DIAMETER SPHERE TO PASS THROUGH THE OPENING WHERE THE OPENING IS IN ITS LARGEST OPENED POSITION.
2. OPERABLE WINDOWS THAT ARE PROVIDED WITH WINDOW FALL PREVENTION DEVICE THAT COMPLY WITH ASTM F 2090

R314 SMOKE ALARMS:

R314.3 LOCATIONS. SMOKE ALARMS SHALL BE INSTALLED IN THE FOLLOWING LOCATIONS:

1. IN EACH SLEEPING ROOM

2. OUTSIDE EACH SEPARATE SLEEPING AREA IN THE IMMEDIATE VICINITY OF THE BEDROOMS.

3. ON EACH ADDITIONAL STORY OF THE DWELLING, INCLUDING BASEMENT AND HABITABLE ATTICS, IN DWELLINGS, OR DWELLING UNITS WITH SPLIT LEVELS AND WITHOUT A INTERVENING DOOR BETWEEN THE ADJACENT LEVELS. A SMOKE ALARM INSTALLED ON THE UPPER LEVEL SHALL SUFFICE FOR THE ADJACENT LOWER LEVEL PROVIDED THAT LOWER LEVEL IS LESS THAN ONE FULL STORYBELOW THE UPPER LEVEL.

4. SMOKE ALARMS SHALL BE INSTALLED NOT LESS THAN 3 FEET HORIZONTALLY FROM THE DOOR OR OPENING OF A BATHROOM THAT CONTAINS A BATHTUB OR SHOWER UNLESS THIS WOULD PREVENT PLACEMENT OF A SMOKE ALARM REQUIRED BY SECTION R314.3

R314.6 POWER SOURCE. SMOKE ALARMS SHALL RECEIVE THEIR PRIMARY POWER FROM THE BUILDING WIRING WHERE SUCH WIRING IS SERVED FROM A COMMERCIAL SOURCE AND, WHERE PRIMARY POWER IS INTERRUPTED, SHALL RECEIVE POWER FROM A BATTERY. WIRING SHALL BE PERMANENT AND WITHOUT A DISCONNECTING SWITCH OTHER THAN THOSE REQUIRED FOR OVERCURRENT PROTECTION.

R314.5 COMBINATION ALARMS

COMBINATION SMOKE AND CARBON MONOXIDE ALARMS SHALL BE PERMITTED TO BE USED IN LIEU OF SMOKE ALARMS.

R315 CARBON MONOXIDE ALARMS

R315.2.1 NEW CONSTRUCTION. FOR NEW CONSTRUCTION, CARBON MONOXIDE ALARMS SHALL BE PROVIDED IN DWELLING UNITS WHERE EITHER OR BOTH OF THE FOLLOWING CONDITION EXIST.

1. THE DWELLING UNIT CONTAINS A FUEL FIRED APPLIANCE.

2. THE DWELLING UNIT HAS AN ATTACHED GARAGE WITH AN OPENING THAT COMMUNICATES WITH THE DWELLING UNIT.

R315.5 POWER SOURCE. CARBON MONOXIDE ALARMS SHALL RECEIVE THEIR PRIMARY POWER FROM THE BUILDING WIRING WHERE SUCH WIRING IS SERVED FROM A COMMERCIAL SOURCE AND, WHERE PRIMARY POWER IS INTERRUPTED, SHALL RECEIVE POWER FROM A BATTERY. WIRING SHALL BE PERMANENT AND WITHOUT A DISCONNECTING SWITCH OTHER THAN THOSE REQUIRED FOR OVERCURRENT PROTECTION.

R310 EMERGENCY ESCAPE AND RESCUE OPENINGS

R310.1 EMERGENCY ESCAPE AND RESCUE OPENING REQUIRED. BASEMENT, HABITABLE ATTICS AND EVERY SLEEPING ROOM SHALL HAVE NOT LESS THAN ONE OPERABLE EMERGENCY ESCAPE AND RESCUE OPENING, WHERE BASEMENTS CONTAIN ONE OR MORE SLEEPING ROOMS, AN EMERGENCY ESCAPE AND RESCUE OPENING SHALL BE REQUIRED IN EACH SLEEPING ROOM. EMERGENCY ESCAPE AND RESCUE OPENINGS SHALL OPEN DIRECTLY INTO A PUBLIC WAY, OR TO A YARD OR COURT THAT OPENS TO A PUBLIC WAY.

R310.2.1 MINIMUM OPENING AREA. EMERGENCY AND ESCAPE RESCUE OPENING SHALL HAVE A NET CLEAR OPENING OF NOT LESS THAN 5.7 SQUARE FEET. THE NET CLEAR OPENING DIMENSIONS REQUIRED BY THIS SECTION SHALL BE OBTAINED BY THE NORMAL OPERATION OF THE EMERGENCY ESCAPE AND RESCUE OPENING FROM THE INSIDE. THE NET CLEAR HEIGHT OPENING SHALL BE NOT LESS THAN 24 INCHES AND THE NET CLEAR WIDTH SHALL BE NOT LESS THAN 20 INCHES.

R310.2.2 WINDOW SILL HEIGHT. WHERE A WINDOW IS PROVIDED AS THE EMERGENCY ESCAPE AND RESCUE OPENING, IT SHALL HAVE A SILL HEIGHT OF NOT MORE THAN 44 INCHES ABOVE THE FLOOR.

R310.2.3 WINDOW WELLS. THE HORIZONTAL AREA OF THE WINDOW WELL SHALL BE NOT LESS THAN 9 SQUARE FEET, WITH THE HORIZONTAL PROJECTION AND WIDTH OF NOT LESS THAN 36 INCHES. THE AREA OF THE WINDOW WELL SHALL ALLOW THE EMERGENCY ESCAPE AND RESCUE OPENINGS TO BE FULLY OPENED.

R311 MEANS OF EGRESS

R311.2 EGRESS DOOR.

NOT LESS THAN ONE EGRESS DOOR SHALL BE PROVIDED FOR EACH DWELLING UNIT. THE EGRESS DOOR SHALL BE SIDE-HINGED, AND SHALL PROVIDE A CLEAR WIDTH OF NOT LESS THAN 32 INCHES WHERE MEASURED BETWEEN THE FACE OF THE DOOR AND THE STOP, WITH THE DOOR OPEN 90 DEGREES. THE CLEAR HEIGHT OF THE DOOR OPENING SHALL BE NOT LESS THAN 78 INCHES IN HEIGHT MEASURED FROM THE TOP OF THE THRESHOLD TO THE BOTTOM OF THE STOP.

R325 MEZZANINES

R325.2 THE CLEAR HEIGHT ABOVE AND BELOW MEZZANINE FLOOR CONSTRUCTION SHALL BE NOT LESS THAN 7 FEET.

R325.5 MEZZANINES SHALL BE OPEN AND UNOBSTRUCTED TO THE ROOM IN WHICH THEY ARE LOCATED EXCEPT FOR WALLS NOT MORE THAN 42 INCHES IN HEIGHT, COLUMNS, AND POSTS.

R1004 FACTORY BUILT FIREPLACES

R1004.1 GENERAL. FACTORY-BUILT FIREPLACES SHALL BE LISTED AND LABELED AND SHALL BE INSTALLED IN ACCORDANCE WITH THE CONDITIONS OF THE LISTINGS. FACTORY-BUILT FIREPLACES SHALL BE TESTED IN ACCORDANCE WITH UL 127.

R1004.2 HEARTH EXTENSIONS. HEARTH EXTENSIONS OF APPROVED FACTORY-BUILT FIREPLACES SHALL BE INSTALLED IN ACCORDANCE WITH THE LISTING OF THE FIREPLACE. THE HEARTH EXTENSION SHALL BE READILY DISTINGUISHABLE FROM THE SURROUNDING FLOOR AREA. LISTED AND LABELED HEARTH EXTENSIONS SHALL COMPLY WITH UL 1618.

R1005 FACTORY-BUILT CHIMNEYS

R1005.1 LISTING. FACTORY-BUILT CHIMNEYS SHALL BE LISTED AND LABELED AND SHALL BE INSTALLED AND TERMINATED IN ACCORDANCE WITH THE MANUFACTURER'S INSTRUCTIONS.

R1006.1 EXTERIOR AIR

R1006.1.1 FACTORY-BUILT FIREPLACE. EXTERIOR COMBUSTION AIR DUCTS FOR THE FACTORY-BUILT FIREPLACE SHALL BE LISTED COMPONENT OF THE FIREPLACE AND SHALL BE INSTALLED IN ACCORDANCE WITH THE FIREPLACE MANUFACTURER'S INSTRUCTION.

R311.6 HALLWAYS:

THE WIDTH OF HALLWAYS SHALL BE NOT LESS THAN 3 FEET

M1602 RETURN AIR

M1602.2 RETURN AIR OPENINGS. RETURN AIR OPENINGS FOR HEATING, VENTILATION, AND AIR CONDITIONING SYSTEMS SHALL COMPLY ALL OF THE FOLLOWING:

1. OPENINGS SHALL NOT BE LOCATED LESS THAN 10 FEET MEASURED IN ANY DIRECTION FROM AN OPEN COMBUSTION CHAMBER OR DRAFT HOOD OF ANOTHER APPLIANCE LOCATED IN THE SAME ROOM OR SPACE.

2. THE AMOUNT OF RETURN AIR TAKEN FROM ANY ROOM OR SPACE SHALL BE NOT GREATER THAN THE FLOW RATE OF SUPPLY AIR DELIVERED TO SUCH ROOM OR SPACE.

3. RETURN AND TRANSFER OPENING SHALL BE SIZED IN ACCORDANCE WITH THE APPLIANCE OR EQUIPMENT MANUFACTURERS' INSTALLATION INSTRUCTIONS, MANUAL, D OR THE DESIGN OF REGISTERED DESIGN PROFESSIONAL.

4. RETURN AIR SHALL NOT BE TAKEN FROM A CLOSET, BATHROOM, TOILET ROOM, KITCHEN, GARAGE, MECHANICAL ROOM, BOIL ROOM, FURNACE ROOM OR UNCONDITIONED ATTIC.

M1502.4 CLOTHES DRYER:

DRYER EXHAUST DUCTS SHALL CONFORM TO THE REQUIREMENT SECTION M1502.4.1 THROUGH M1502.4.7

R302.5 DWELLING-GARAGE OPENING AND PENETRATION PROTECTION

R302.5.1 OPENING BETWEEN THE GARAGE AND RESIDENCE SHALL BE EQUIPPED WITH SOLID WOOD DOORS NOT LESS THAN 1 ½ INCHES IN THICKNESS, SOLID OR HONEYCOMB-CORE STEEL DOORS NOT LESS THAN 1 ½ THICK, OR 20 MINUTE FIRE RATED DOOR, EQUIPPED WITH A SELF-CLOSING DEVICE.

PROVIDE ONE LAYER 1" GWB TYPE "X" AT CEILINGS COMMON WITH HABITABLE AREAS ABOVE
-WHERE THE SEPARATION IS A FLOOR-CEILING ASSEMBLY, CLAD ALL SUPPORT COLUMNS, BEAMS AND WALLS WITH ONE LAYER 1" GWB.
-THE GARAGE SIDE SHALL BE SEPARATED FROM THE RESIDENCE AND ATTIC AREA WITH NO LESS THAN 1" GWB ON THE GARAGE SIDE.

OPENINGS FROM A PRIVATE GARAGE DIRECTLY INTO A ROOM USED FOR SLEEPING PURPOSE SHALL NOT BE PERMITTED.

R302.5.2 DUCT PENETRATION. DUCTS IN THE GARAGE AND DUCTS PENETRATING THE WALLS OR CEILINGS SEPARATING THE DWELLING FROM THE GARAGE SHALL BE CONSTRUCTED OF A MINIMUM NO. 26 GAGE SHEET STEEL OR OTHER APPROVED MATERIAL AND SHALL NOT HAVE OPENING INTO THE GARAGE.

R807 ATTIC ACCESS:

R807.1 THE ROUGH-FRAMED OPENING SHALL BE NOT LESS THAN 22 INCHES BY 30 INCHES AND SHALL BE LOCATED IN A HALLWAY OR OTHER READILY ACCESSIBLE LOCATION, WHERE LOCATED IN A WALL, THE OPENING SHALL BE NOT LESS THAN 22 INCHES WIDE BY 30 INCHES HIGH, WHERE THE ACCESS IS LOCATED IN THE CEILING, MINIMUM UNOBSTRUCTED HEAD-ROOM IN THE ATTIC SPACE SHALL BE 30 INCHES AT SOME POINT ABOVE THE ACCESS MEASURED VERTICALLY FROM THE BOTTOM OF THE CEILING FRAMING MEMBERS.

R311.7.1 STAIR WIDTH:

STAIRWAYS SHALL NOT BE LESS THAN 36" IN CLEAR WIDTH AT ALL POINTS ABOVE THE HANDRAIL HEIGHT AND BELOW THE REQUIRED HEADROOM HEIGHT. HANDRAILS SHALL NOT PROJECT MORE THAN 4-1/2" ON EITHER SIDE OF THE STAIRWAY AND THE MINIMUM CLEAR WIDTH OF THE STAIRWAY AT AND BELOW THE HANDRAIL HEIGHT, INCLUDING TREADS AND LANDINGS, SHALL NOT BE LESS THAN 31-1/2" WHERE THE HANDRAIL IS INSTALLED ON ONE SIDE AND 27" WHERE HANDRAILS ARE INSTALLED ON BOTHE SIDES.

R311.7.5.1 RISERS

THE RISER HEIGHT SHALL BE NOT MORE THAN 7 ½ INCHES. THE RISER TO BE MEASURED VERTICALLY BETWEEN LEADING EDGES OF THE ADJACENT TREADS. THE GREATEST RISER HEIGHT WITHIN ANY FLIGHT OF STAIRS SHALL NOT EXCEED THE SMALLEST BY MORE THAN ¾ INCH.

OPEN RISERS ARE PERMITTED PROVIDED THAT THE OPENING LOCATE MORE THAN 30 INCHES, AS MEASURED VERTICALLY, TO THE FLOOR OR GRADE BELOW DO NOT PERMIT THE PASSAGE OF 4 INCHES DIAMETER SPHERE.

R311.7.5.2 TREADS

THE TREAD DEPTH SHALL BE NOT LESS THAN 10 INCHES. THE TREAD DEPTH SHALL BE MEASURED HORIZONTALLY BETWEEN THE VERTICAL PLANES OF THE FOREMOST PROJECTION OF ADJACENT TREADS AND AT A RIGHT ANGLE TO THE TREAD'S LEADING EDGE. THE GREATEST TREAD DEPTH WITHIN ANY FLIGHT OF STAIRS SHALL NOT EXCEED THE SMALLEST BY MORE THAN ¾ INCH.

R311.7.10.1 SPIRAL STAIRS:

SPIRAL STAIRWAYS ARE PERMITTED, PROVIDED THAT THE CLEAR WIDTH AT AND BELOW THE HANDRAIL IS NOT LESS THAN 26 INCHES AND THE WALKLINE RADIUS IS NOT GREATER THAN 24 ½ INCHES. EACH TREAD SHALL HAVE A DEPTH OF NOT LESS THAN 6 ½ INCHES AT THE WALKLINE. ALL TREADS SHALL BE IDENTICAL, AND THE RISE SHALL BE NOT MORE THAN 9 ½ INCHES. HEADROOM SHALL BE NOT LESS THAN 6 FEET 6 INCHES.

R311.7.9 ILLUMINATION:

STAIRWAYS SHALL BE PROVIDED WITH ILLUMINATION IN ACCORDANCE WITH SECTION R303.7

R308-SAFETY GLAZING

R308.4 HAZARDOUS LOCATIONS. THE LOCATIONS SPECIFIED IN SECTIONS R308.4.1 TO R.308.4.7 SHALL BE CONSIDERED TO BE SPECIFIC HAZARDOUS LOCATIONS FOR THE PURPOSE OF GLAZING.

R308.4.1 GLAZING IN DOORS. GLAZING IN FIXED AND OPERABLE PANELS OF SWINGING, SLIDING, AND BIFOLD DOORS SHALL BE CONSIDERED TO BE A HAZARDOUS LOCATION.

R308.4.2 GLAZING ADJACENT TO DOORS. GLAZING IN AN INDIVIDUAL FIXED OR OPERABLE PANEL ADJACENT TO A DOOR SHALL BE CONSIDERED A HAZARDOUS LOCATION WHERE THE BOTTOM EXPOSED EDGE OF THE GLAZING IS LESS THAN 60 INCHES ABOVE THE FLOOR OR WALKING SURFACE AND IT MEETS EITHER OF THE FOLLOWING CONDITIONS:

1. WHERE THE GLAZING IS WITHIN 24 INCHES OF EITHER SIDE OF THE DOOR IN THE PLANE OF THE DOOR IN A CLOSED POSITION.
2. WHERE THE GLAZING IS ON A WALL PERPENDICULAR TO THE PLANE OF THE DOOR IN A CLOSED POSITION AND WITHIN 24 INCHES OF THE HINGE SIDE OF AN IN-SWINGING DOOR

R308.4.3 GLAZING IN WINDOWS. GLAZING IN AN INDIVIDUAL FIXED OR OPERABLE PANEL THAT MEETS ALL OF THE FOLLOWING CONDITIONS SHALL BE CONSIDERED TO BE A HAZARDOUS LOCATION:

1. THE BOTTOM EDGE OF THE GLAZING IS LESS THAN 18 INCHES ABOVE THE FLOOR

R308.4.5 GLAZING AND WET SURFACES. GLAZING IN WALLS, ENCLOSURES OR FENCES CONTAINING OR FACING HOT TUBS, SPAS, WHIRLPOLS, SAUNAS, STEM ROOMS, BATHTUBS, SHOWERS AND INDOOR OR OUTDOOR SWIMMING POOLS WHERE THE BOTTOM EXPOSED EDGE OF THE GLAZING IS LESS THAN 60 INCHES (1524 MM) MEASURED VERTICALLY ABOVE ANY STANDING OR WALKING SURFACE SHALL BE CONSIDERED TO BE A HAZARDOUS LOCATION. THIS SHALL APPLY TO SINGLE GLAZING AND EACH PANE IN MULTIPLE GLAZING.

R308.4.6 GLAZING ADJACENT TO STAIRS AND RAMPS. GLAZING WHERE THE BOTTOM EXPOSED EDGE OF THE GLAZING IS LESS THAN 36 INCHES (914 MM) ABOVE THE PLANE OF THE ADJACENT WALKING SURFACES OF STAIRWAYS, LANDINGS, S BETWEEN FLIGHTS OF STAIRS AND RAMPS SHALL BE CONSIDERED TO BE A HAZARDOUS LOCATION

R308.4.7 GLAZING ADJACENT TO THE BOTTOM STAIR LANDING AT THE BOTTOM OF THE STAIRWAY WHERE THE GLAZING IS LESS THAN 36 INCHES ABOVE THE LANDING AND WITHIN A 60 INCHES HORIZONTAL ARCH LESS THAN 180 DEGREES FROM THE BOTTOM TREAD NOSING SHALL BE CONSIDERED TO BE A HAZARDOUS LOCATION.

2015 ENERGY GLAZING:

U-FACTORS OF FENESTRATION PRODUCTS (WINDOWS, DOORS AND SKYLIGHTS) SHALL BE DETERMINED IN ACCORDANCE WITH NFRC 100 BY AN ACCREDITED, INDEPENDENT LABORATORY. WINDOWS SHALL BE NFRC CERTIFIED OR USE DEFAULT GLAZE FENESTRATION VALUES, PER 303.1.3

| INSULATION AND FENESTRATION REQUIREMENTS BY COMPONENT | |
|---|-------------------|
| CLIMATE ZONE | 5 AND MARINE 4 |
| FENESTRATION U-FACTOR * | 0.28 |
| SKYLIGHT D-FACTOR | 0.50 |
| GLAZED FENESTRATION SHGC ** | NR |
| CEILING R-VALUE | 49 |
| WOOD FRAME WALL - R-VALUE | 21 int |
| Mass Wall R-Value | 21/21 |
| FLOOR R-VALUE | 38 |
| BELOW-GRADE WALL R-VALUE | 10/15/21 int + TB |
| SLAB R-VALUE & DEPTH | 10, 2 ft |

| TABLE 406.2-ENERGY CREDITS | | |
|----------------------------|--|-----------|
| OPTION | DESCRIPTION | CREDIT(S) |
| 1a | EFFICIENT BUILDING ENVELOPE 1a | 0.5 |
| 1b | EFFICIENT BUILDING ENVELOPE 1b | 1.0 |
| 1c | EFFICIENT BUILDING ENVELOPE 1c | 2.0 |
| 1d | EFFICIENT BUILDING ENVELOPE 1d | 0.5 |
| 2a | AIR LEAKAGE CONTROL AND EFFICIENT VENTILATION 2a | 0.5 |
| 2b | AIR LEAKAGE CONTROL AND EFFICIENT VENTILATION 2b | 1.0 |
| 2c | AIR LEAKAGE CONTROL AND EFFICIENT VENTILATION 2c | 1.5 |
| 3a | HIGH EFFICIENT HVAC EQUIPMENT 3a | 1.0 |
| 3b | HIGH EFFICIENT HVAC EQUIPMENT 3b | 1.0 |
| 3c | HIGH EFFICIENT HVAC EQUIPMENT 3c | 1.5 |
| 3d | HIGH EFFICIENT HVAC EQUIPMENT 3d | 1.0 |
| 4 | HIGH EFFICIENCY HVAC DISTRIBUTION SYSTEM | 1.0 |
| 5a | EFFICIENT WATER HEATING 5a | 0.5 |
| 5b | EFFICIENT WATER HEATING 5b | 1.0 |
| 5c | EFFICIENT WATER HEATING 5c | 1.5 |
| 5d | EFFICIENT WATER HEATING 5d | 0.5 |
| 6 | RENEWABLE ELECTRIC ENERGY | 0.5 |

FOOTNOTES:

a. PROJECTS USING THIS OPTION MAY NOT USE OPTION 1a, 1b or 1c.

b. PROJECTS MAY ONLY INCLUDE CREDIT FROM ONE SPACE HEATING OPTION, 3a, 3b, 3c or 3d, WHEN A HOUSING UNIT HAS TWO PIECES OF EQUIPMENT (I.E., TWO FURNACES) BOTH MUST MEET THE STANDARD TO RECEIVE THE CREDIT.

c. PLUMBING FIXTURES FLOW RATINGS. LOW FLOW PLUMBING FIXTURES (WATER CLOSETS AND URINALS) AND FITTINGS (FAUCETS AND SHOWERHEADS) SHALL COMPLY WITH THE FOLLOWING REQUIREMENTS:

- RESIDENTIAL BATHROOM LAVATORY SINK FAUCETS: MAXIMUM FLOW RATE-3.8L/MIN (1.0 GAL/MIN) WHEN TESTED IN ACCORDANCE WITH ASME A112.18.1.1CSA B125.1.
- RESIDENTIAL KITCHEN FAUCETS: MAXIMUM FLOW RATE-6.6 L/MIN (1.75 GAL/MIN) WHEN TESTED IN ACCORDANCE WITH ASME A 112.18.1CSA B125.1.
- RESIDENTIAL SHOWERHEADS: MAXIMUM FLOW RATE-6.6 L/MIN (1.75 GAL/MIN) WHEN TESTED IN ACCORDANCE WITH ASME A112.18.1.1CSA B125.1.

M1507 MECHANICAL VENTILATION

M1507.1 GENERAL. WHERE LOCAL EXHAUST OR WHOLE-HOUSE MECHANICAL VENTILATION IS PROVIDED, THE EQUIPMENT SHALL BE DESIGNED IN ACCORDANCE WITH THIS SECTION & TABLE BELOW:

| DUCT TYPE | FLEX DUCT | | | | | | SMOOTH-WALL DUCT | | | | | | | | | |
|--|-----------|----|-----|-----|-----|-----|------------------|-----|-----------------------|----|-----|-----|-----|-----|-----|-----|
| | 50 | 80 | 100 | 125 | 150 | 200 | 250 | 300 | 50 | 80 | 100 | 125 | 150 | 200 | 250 | 300 |
| FAN AIRFLOW RATING (CFM @ 0.25 INCH wc) a | | | | | | | | | | | | | | | | |
| Diameter b (inches) | | | | | | | | | Maximum length (feet) | | | | | | | |
| 3 | x | x | x | x | x | x | x | x | 5 | x | x | x | x | x | x | x |
| 4 | 56 | 4 | x | x | x | x | | | | | | | | | | |

ROOF VENTS CAL.:
 CONT. RIDGE VENT REQ'S:
 - 445/300 = 1.84 SQ.FT.
 CONT. RIDGE VENT APPLY:
 1.84/(1.25'/12) = 14.24 LF

NOTES:
 *A COPY OF THE ICC-ES REPORT FOR THE INSULATION PRODUCT MUST BE PROVIDED ON SITE FOR THE FIELD INSPECTOR.
 THE APPLIED SPRAY FORM MUST BE INSTALLED IN ACCORDANCE WITH THE MANUFACTURER'S INSTRUCTIONS BY A CERTIFIED INSTALLER.

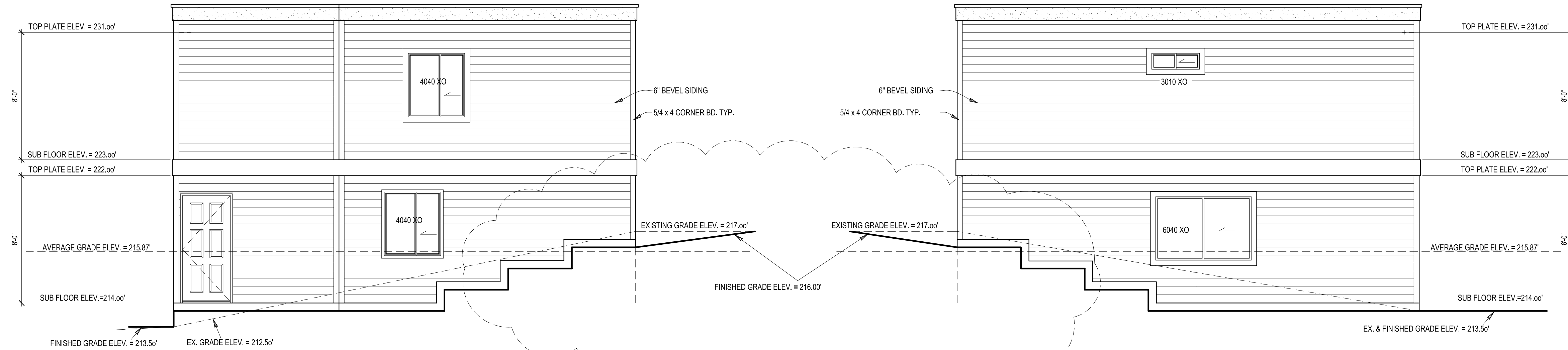

WEST ELEVATION

EAST ELEVATION

NOTE: PROVIDE CONTINUOUS PRE-PAINTED GN. "Z" FLASHING AT ALL EXT. DOOR & WINDOW HEADERS.

- VERIFY SHEAR WALL NAILING AND HOLD-DOWNS ARE PER PLAN AND SCHEDULE PRIOR TO INSTALLING SIDING
- MASONRY AND WOOD FRAME CHIMNEYS ARE TO BE CONSTRUCTED PER I.R.C.
- PROVIDE GALVANIZED SHEET METAL FLASHING AND COUNTERFLASHING AT ALL ROOF / WALL INTERSECTIONS, CHIMNEYS, AND SKYLIGHTS
- PROVIDE WEATHERSTRIPPING AND FLASHING AT ALL DOORS AND WINDOWS AS REQUIRED
- CAULK ALL EXTERIOR JOINTS AND PENETRATIONS
- POST ADDRESS ON BLDG. PRIOR TO FINAL INSPECTION
- LOTS SHALL BE GRADED AS TO DRAIN SURFACE WATER AWAY FROM FOUNDATION WALL. SLOPE SHALL BE 6" IN FIRST 10 FT. OR DRAINS OR SWALES SHALL BE PROVIDED TO ENSURE DRAINAGE AWAY FROM STRUCTURE
- FASTENERS TO BE HOT-DIPPED GALV. STEEL, STAINLESS OR ALUM. (CORROSION RESISTANT)

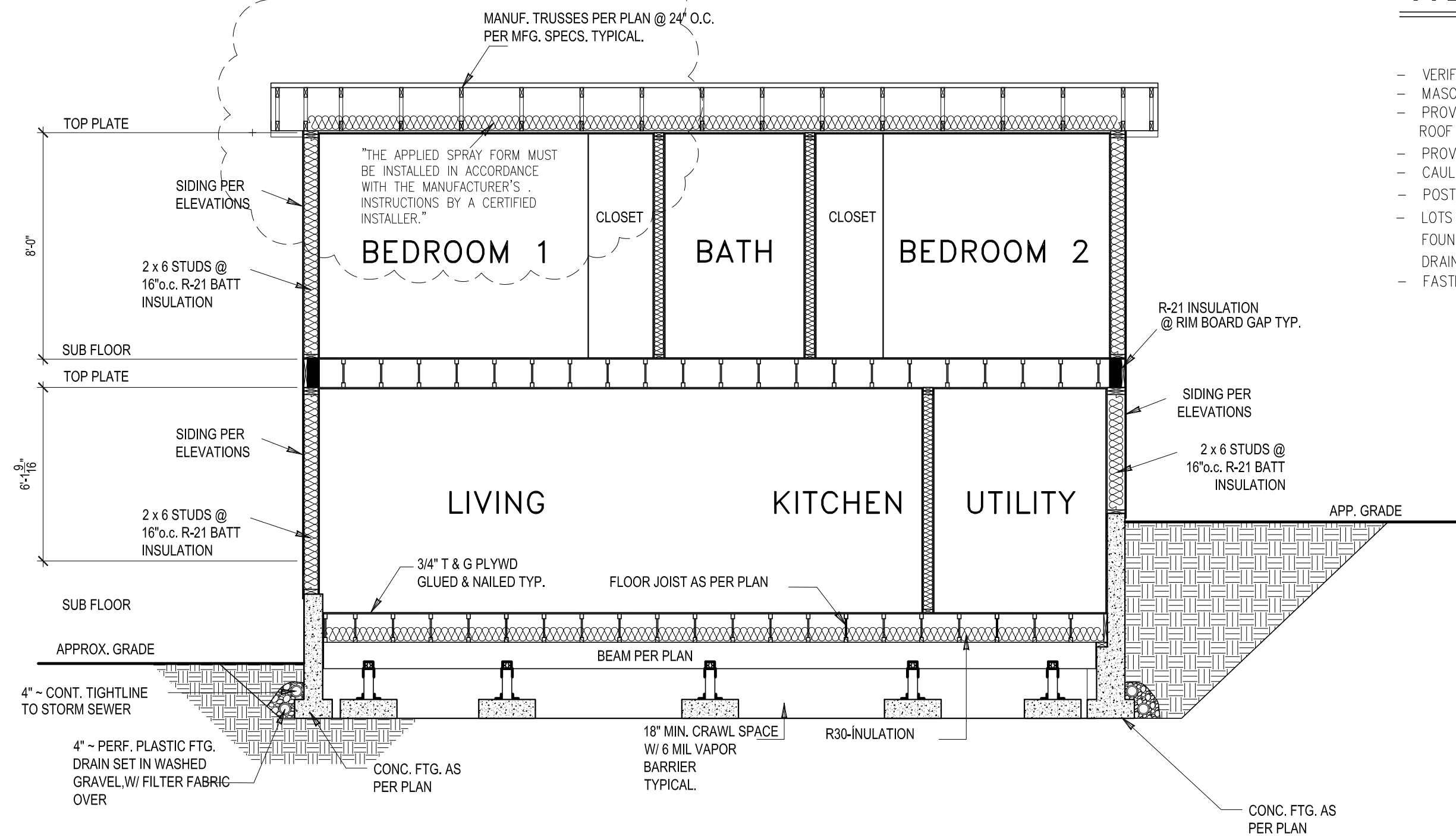

TYPICAL HOUSE SECTION (AA)

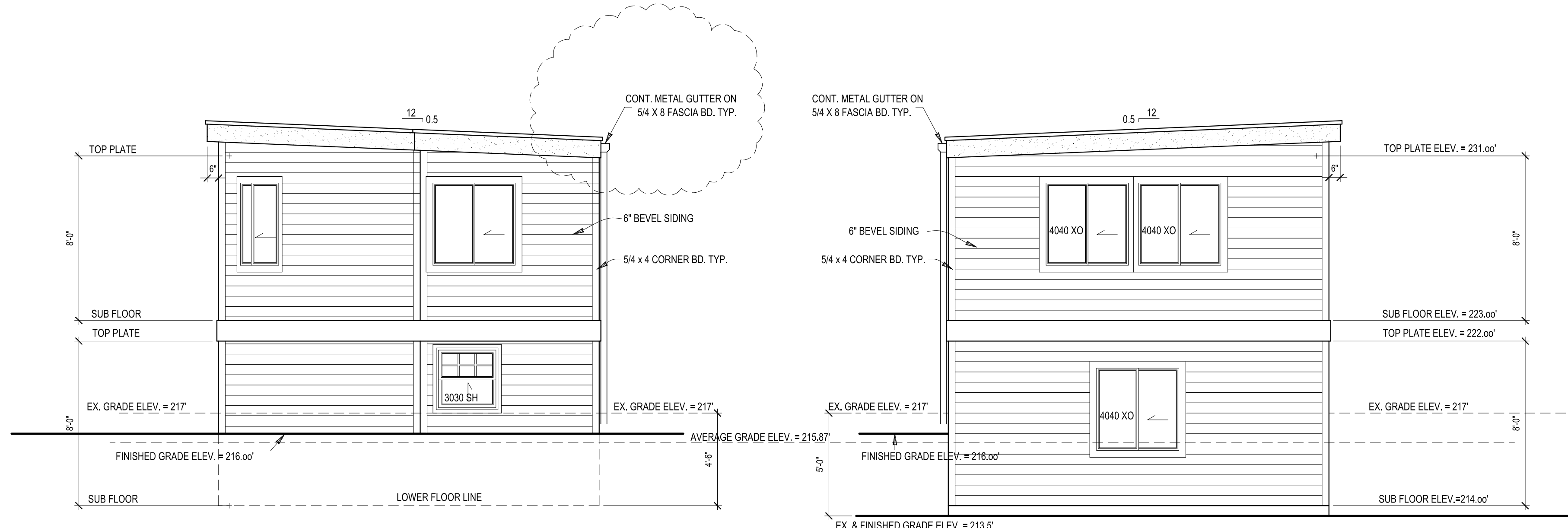

SOUTH ELEVATION

NORTH ELEVATION

NOTE: REFER TO STRUCTURAL SHEETS FOR SHEAR WALL SCHEDULE AND ENGINEERING PLAN WHICH CONTAIN DETAIL REFERENCES AND/OR INSTRUCTIONS PERTAINING TO EACH SHEAR WALL INDICATED IN THIS PLAN.

NOTE: CONTRACTOR TO VERIFY ALL DIMENSIONS AND CONDITIONS OF PROJECT AND REPORT ANY OMISSIONS / DISCREPANCIES TO DESIGNER PRIOR TO COMMENCING WORK. DESIGNER SHALL NOT BE RESPONSIBLE FOR DISCREPANT CONDITIONS RESULTING FROM UNAUTHORIZED WORK PERFORMED BY THE CONTRACTOR.

*** NO FIELD ALTERATIONS WILL BE AUTHORIZED UNLESS ACCOMPANIED BY REVISED DRAWINGS.**

| DATE | REVISION | REV. BY: |
|------|----------|----------|
| | | |
| | | |
| | | |

PREPARED BY:
T & L HOME DESIGN
 ARCHITECTURAL-ENGINEERING-DESIGN
 1721 E. 60th ST. PHONE: 253-441-1651
 TACOMA, WA 98404 Email: trucwa@yahoo.com

PREPARED FOR:
YOUNG CHUNG RESIDENCE/ADU
NEW CONSTRUCTION
 7002 78th AVE. SE. MERCER ISLAND 98040
 PARCEL NUMBER: 252404-9217

| | | |
|---|--|---|
| PAYMENT OF USES FEE IS DUE TO T & L HOME DESIGN PRIOR TO CONSTRUCTION FOR EACH STRUCTURE BUILT FROM THESE PLANS. THESE PLANS ARE COPYRIGHTED IN ACCORDANCE WITH FEDERAL STATUTES. REPRODUCTION BY ANY METHOD OF ALL OR PORTIONS OF THESE PLANS OR VARIATIONS THEREOF WITHOUT WRITTEN PERMISSION FROM T & L HOME DESIGN IS STRICTLY PROHIBITED. THESE DRAWINGS AND PLANS SET FORTH ON THIS SHEET AS INSTRUMENTS OF SERVICE ARE, AND SHALL REMAIN TO THE PROPERTY OF T & L HOME DESIGN. | BY: T.N. DATE: 7-27-20 CHECKED: T.N. SHEET # A2 | Elevations PROJECT # TL-20-12 |
|---|--|---|

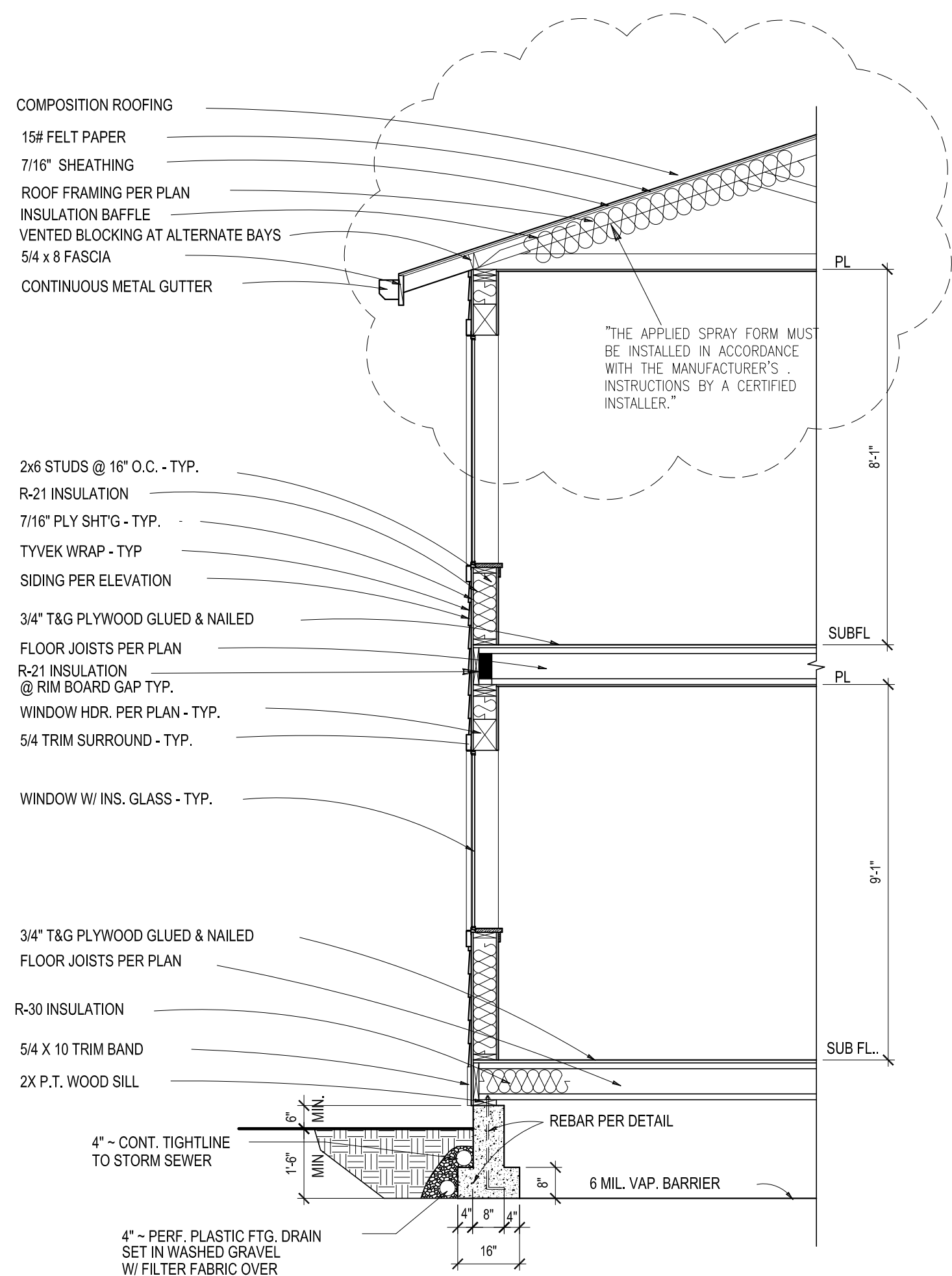

TYPICAL WALL SECTION AT HOUSE

N.T.S.

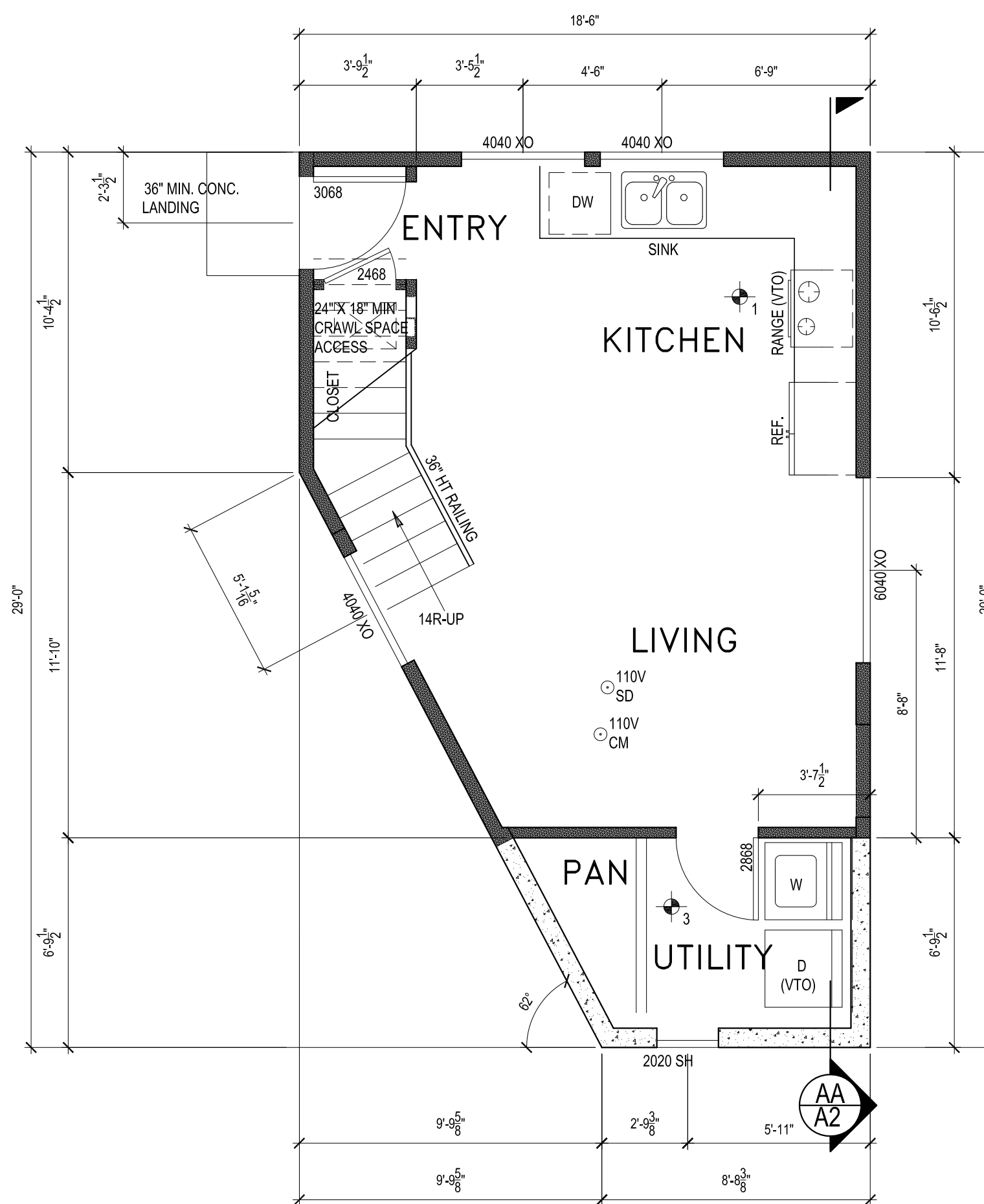

MAIN FLOOR PLAN = 400 SF

SCALE : 1/4" = 1'-0"

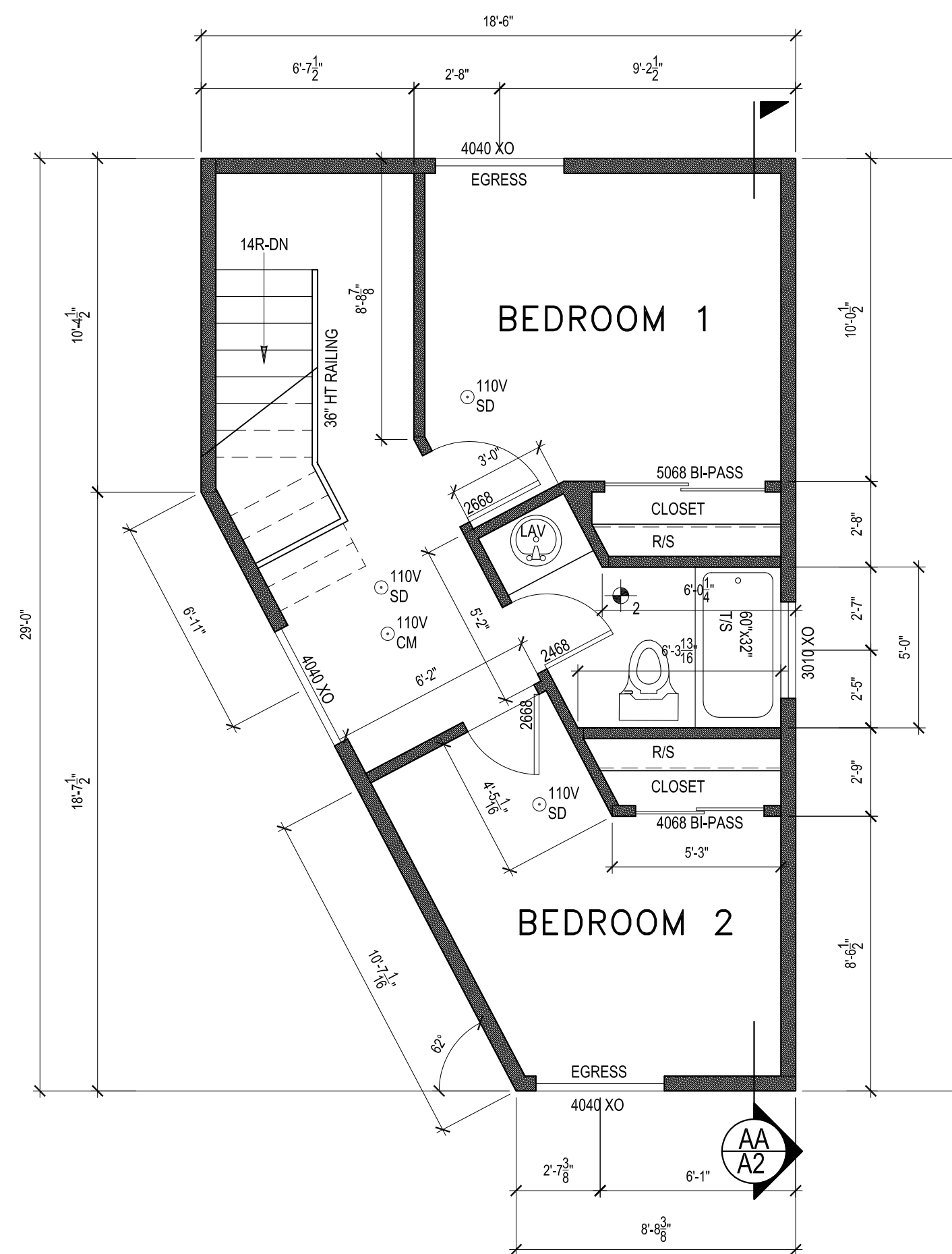

UPPER FLOOR PLAN = 445 SF.

SCALE : 1/4" = 1'-0"

NOTES:
 A WRITTEN REPORT OF THE TEST RESULTS BE SIGNED BY THE TESTING PARTY AND PROVIDED TO THE BUILDING INSPECTOR. PRIOR TO CALL FOR INSPECTION: THE AIR LEAKAGE TEST RESULT SHALL BE DOCUMENTED ON THE FORM WHICH IS AVAILABLE ON-LINE AT: [HTTP://WWW.ENERGY.SVU.EDU/BUILDINGEFFICIENCY/ENERGYCODE.ASPX](http://www.energy.svu.edu/buildingefficiency/energycode.aspx). BUILDER SHALL COMPLETE AND POST AN "INSULATION CERTIFICATE FOR RESIDENTIAL CONSTRUCTION" WITHIN 3' OF ELECTRICAL PANEL PRIOR TO FINAL INSPECTION. PROVIDE A PROGRAMMABLE THERMOSTAT FOR THE PRIMARY SPACE CONDITIONING SYSTEM WITHIN THE DWELLING UNIT.

NOTE:
 REFER TO STRUCTURAL SHEETS FOR SHEAR WALL SCHEDULE AND ENGINEERING PLAN WHICH CONTAIN DETAIL REFERENCES AND/OR INSTRUCTIONS PERTAINING TO EACH SHEAR WALL INDICATED IN THIS PLAN.

AREA SUMMARY

| | |
|---------------|----------------|
| UPPER LEVEL: | 445 SF. |
| LOWER LEVEL: | 400 SF. |
| TOTAL: | 845 SF. |

LIGHTING SECTION

(IECC/SEC R404) A MINIMUM OF 75% OF PERMANENTLY INSTALLED LAMPS IN LIGHT ALL LIGHTING FIXTURES SHALL BE HIGH-EFFICACY LAMPS

LUMINAIRES PROVIDING OUTDOOR LIGHTING AND PERMANENTLY MOUNTED TO A RESIDENTIAL BUILDING OR TO OTHER BUILDING ON THE SAME LOT SHALL BE HIGH EFFICACY LUMINAIRES

SMOKE DETECTORS

INSTALL SMOKE DETECTORS PER CODE, 110V/9V INTERCONNECTED

CARBON MONOXIDE ALARM
 NEW CONSTRUCTION, AN APPROVED CARBON MONOXIDE ALARM SHALL BE INSTALLED OUTSIDE OF EACH SEPERATE SLEEPING AREA IN THE IMMEDIATE VICINITY OF THE BEDROOMS, SEE SECTION R315

VENTILATION SCHEDULE

MINIMUM SOURCE SPECIFIC VENTILATION CAPACITY REQ. TABLE M1507.4

| SYMBOL | ROOMS | VENTILATION CAPACITY |
|--------|--|---|
| 1 | KITCHENS | 100 CFM INTERMITTENT OR 25 CFM CONTINUOUS |
| 2 | BATHROOMS, TOILET ROOMS AND LAUNDRY/UTILITY ROOM | MECHANICAL EXHAUST CAPACITY OF 50 CFM INTERMITTENT OR 20 CFM CONTINUOUS |
| 3 | WHOLE HOUSE FAN | 60 CF. CONTINUOUS (WHOLE HOUSE FAN LOCATED (INSIDE LAUNDRY/UTILITY U.N.O.)) |

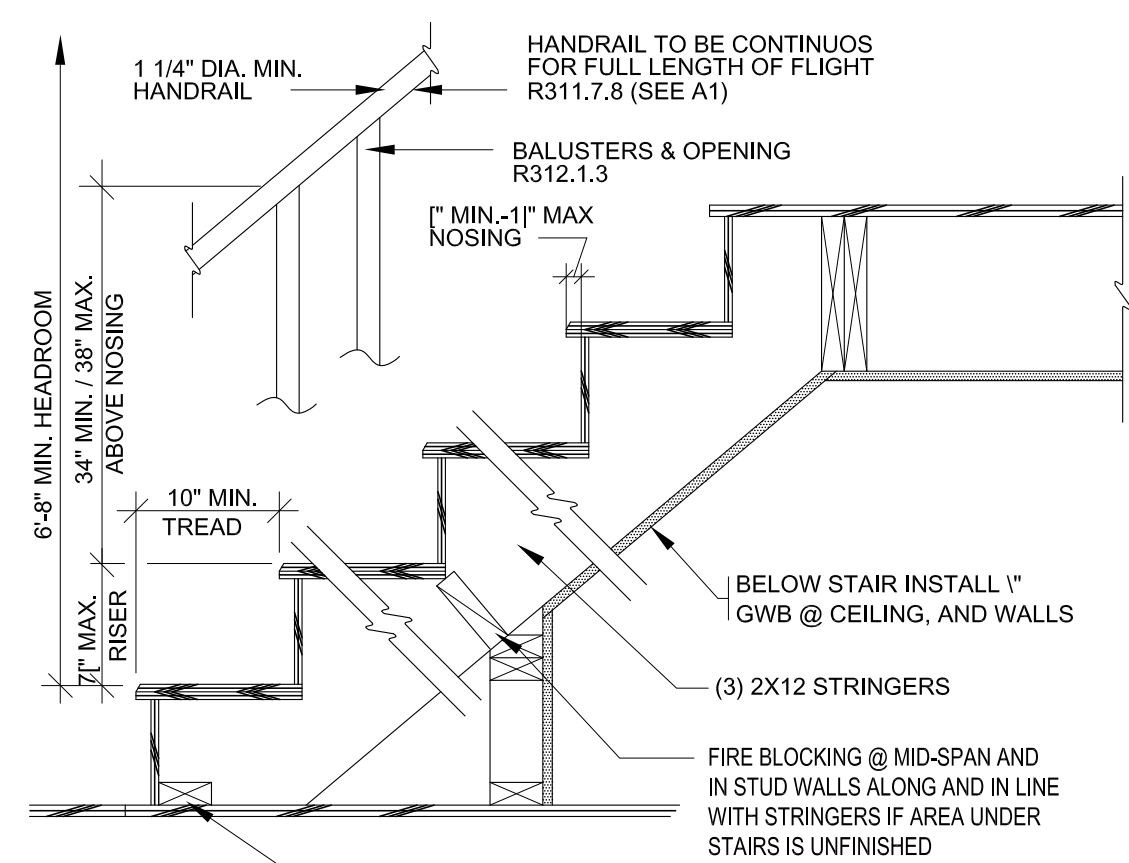

1 STAIR DETAIL

N.T.S.

ADDITIONAL STAIR NOTE PLEASE REFER TO SHEET A1

2015 STATE ENERGY CODE (WSEC)

ENERGY CREDIT OPTION SHALL BE USE FOR THIS PROJECT.

OPTION 5a -Kitchen Sink and Showerhead < 1.75 GPM, lavatory faucets < 1.0 GPM = 0.5 CREDITS
 OPTION 5c -Gas water heater > 0.91EF OR electric water heater > 2.0 EF = 1.0 CREDITS

TOTAL = 1.5 CREDITS

NOTE:
 HEATING EQUIPMENT SIZE FORM TO BE SUBMITTED TO INSPECTOR, SEPARATELY UPLOADED FROM PLAN SET.

NOTE:
 CONTRACTOR TO VERIFY ALL DIMENSIONS AND CONDITIONS OF PROJECT AND REPORT ANY OMISSIONS / DISCREPANCIES TO DESIGNER PRIOR TO COMMENCING WORK. DESIGNER SHALL NOT BE RESPONSIBLE FOR DISCREPANT CONDITIONS RESULTING FROM UNAUTHORIZED WORK PERFORMED BY THE CONTRACTOR.

NOTE:
 EXHAUST FAN VENTS SHALL TERMINATE OUTDOOR AND NOT IN ATTIC, SOFFITS, RIDGE VENT OR IN CRAWL SPACE. EXHAUST VENT CLEARANCES MUST BE 3 FEET FROM PROPERTY LINE 3 FEET FROM OPERABLE OPENINGS INTO THE BUILDING AND 10 FEET FROM MECHANICAL AIR INTAKE.

NOTE:
 PROVIDE A PROGRAMMABLE THERMOSTAT FOR THE PRIMARY SPACE CONDITIONING SYSTEM WITHIN THE DWELLING UNIT.

NOTE:
 BUILDER SHALL COMPLETE AND POST AN "INSULATION CERTIFICATE FOR RESIDENTIAL CONSTRUCTION" WITHIN 3' OF ELECTRICAL PANEL PRIOR TO FINAL INSPECTION.

* NO FIELD ALTERATIONS WILL BE AUTHORIZED UNLESS ACCOMPANIED BY REVISED DRAWINGS.

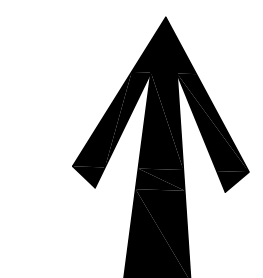

NORTH

| DATE | REVISION | REV. BY: |
|------|----------|----------|
| | | |
| | | |
| | | |

PREPARED BY:
T & L HOME DESIGN
 ARCHITECTURAL-ENGINEERING-DESIGN
 1721 E. 60st ST. PHONE: 253-441-1651
 TACOMA, WA 98404 Email: trucwa@yahoo.com

PREPARED FOR:
YOUNG CHUNG RESIDENCE/ADU
NEW CONSTRUCTION
 7002 78th AVE. SE. MERCER ISLAND 98040
 PARCEL NUMBER: 252404-9217

PAYMENT OF USES FEE IS DUE TO T & L HOME DESIGN PRIOR TO CONSTRUCTION FOR EACH STRUCTURE BUILT FROM THESE PLANS. THESE PLANS ARE COPYRIGHTED IN ACCORDANCE WITH FEDERAL STATUTES. REPRODUCTION BY ANY METHOD OF ALL OR PORTIONS OF THESE PLANS OR VARIATIONS THEREOF WITHOUT WRITTEN PERMISSION FROM T & L HOME DESIGN IS STRICTLY PROHIBITED. THESE DRAWINGS AND PLANS SET FORTH ON THIS SHEET AS INSTRUMENTS OF SERVICE ARE, AND SHALL REMAIN TO THE PROPERTY OF T & L HOME DESIGN.

BY: T.N.
 DATE: 7-27-20
 CHECKED: T.N.
 SHEET # **A3**

Floor plans
 PROJECT # **TL-20-12**
3

GENERAL NOTES

BUILDING CODE

2015 IBC EDITION OF THE INTERNATIONAL BUILDING CODE AS AMENDED BY LOCAL JURISDICTION.
 ROOF LIVE LOAD = 25 PSF (SNOW)
 ROOF DEAD LOAD = 15 PSF
 FLOOR LIVE LOAD = 40 PSF (REDUCIBLE)
 FLOOR DEAD LOAD = 12 PSF
 FLOOR LIVE LOAD = 60 PSF FOR DECK/BALCONY
 WIND LOAD = 110 MPH WIND SPEED, EXPOSURE "C"
 SOIL SITE CLASS "D"
 CONSTRUCTION TYPE: V-B
 OCCUPANCY GROUP: R-3

DEFERRED SUBMITTAL ITEMS

THE FOLLOWING IS A LIST OF ITEMS THAT ARE NOT INCLUDED IN THIS PLAN AND SHOULD BE PROVIDED BY THE BUILDER AT TIME OF APPLICATION FOR PERMIT OR AS A DEFERRED SUBMITTAL ITEM:
 - ALTERNATIVE I-JOIST/BEAM MANUFACTURER PLANS.
 - TRUSS DESIGN FOR ROOF FRAMING
 - ELECTRICAL PLANS & SPECIFICATIONS (IF REQUIRED)

SITE WORK

GENERAL

UNLESS A SOILS INVESTIGATION BY A QUALIFIED SOILS ENGINEER IS PROVIDED, FOUNDATION DESIGN IS BASED ON AN AVERAGE SOIL BEARING OF 2000 PSF PER SOILS REPORT. EXTERIOR FOOTINGS SHALL BEAR 18" (MINIMUM) BELOW FINISHED GRADE. ALL FOOTINGS TO BEAR ON FIRM UNDISTURBED EARTH BELOW ORGANIC SURFACE SOILS. BACKFILL TO BE THOROUGHLY COMPACTED.

BOLTS HEADS AND NUTS BEARING AGAINST WOOD TO BE PROVIDED WITH 3"x3"x1/4" PLATE WASHERS. WOOD BEARING ON OR INSTALLED WITHIN 1" OF MASONRY OR CONCRETE TO BE PRESSURE TREATED WITH AN APPROVED PRESERVATIVE.

FOUNDATION SILL BOLTS TO BE 5/8" DIAMETER AT 5'-0" O.C. U.N.O. WITH MIN. 7" EMBEDMENT METAL FRAMING CONNECTORS TO BE MANUFACTURED BY SIMPSON OR APPROVED EQUAL.

CONCRETE

MINIMUM CONCRETE COMPRESSIVE STRENGTH (f_c) AT 28 DAYS TO BE 2,500 PSI WITH 6% AIR ENTRAINMENT +/- 1% (FOR WEATHERING) WITH 5-1/2 MIX SACK CONCRETE "BATCH TICKET" SHALL BE AVAILABLE ON SITE PER BUILDING INSPECTOR REINFORCING STEEL TO COMPLY WITH ASTM A615 GRADE 40 OR BETTER.

LUMBER GRADES

FRAMING LUMBER SHALL COMPLY WITH THE LATEST EDITION OF THE GRADING RULES OF THE WESTERN PRODUCTS ASSOCIATION OR THE WEST COAST LUMBER INSPECTION BUREAU. ALL SAWN LUMBER SHALL BE STAMPED WITH THE GRADE MARK OF AN APPROVED LUMBER GRADING AGENCY AND SHALL HAVE THE

FOLLOWING UNADJUSTED DESIGN MINIMUM PROPERTIES:

| JOISTS: | WOOD TYPE: |
|---------------|---|
| 2X4 | HF #2 - Fb=975 psi, Fv=150 psi, Fc=1300 psi, E=1300000psi |
| 2X6 OR LARGER | HF #2 - Fb=975 psi, Fv=150 psi, Fc=1300 psi, E=1300000psi |
| BEAM | |
| 4X | DF-L #2 - Fb=900 psi, Fv=180 psi, Fc=1350 psi, E=1600000psi |
| 6X OR LARGER | DF-L #2 - Fb=875 psi, Fv=170 psi, Fc=600 psi, E=1300000psi |
| STUDS | |
| 2X4 | HF #2 - Fb=975 psi, Fv=150 psi, Fc=1300 psi, E=1300000psi |
| 2X6 OR LARGER | HF #2 - Fb=975 psi, Fv=150 psi, Fc=1300 psi, E=1300000psi |
| POSTS | |
| 4X4 | HF #2 - Fb=975 psi, Fv=150 psi, Fc=1300 psi, E=1300000psi |
| 4X6 OR LARGER | HF #2 - Fb=975 psi, Fv=150 psi, Fc=1300 psi, E=1300000psi |
| 6X6 OR LARGER | DF-L #2 - Fb=750 psi, Fv=170 psi, Fc=700 psi, E=1300000psi |

GLUED-LAMINATED BEAM (GLB)

SHALL BE 24F-V4 FOR SINGLE SPANS & 24F-V8 FOR CONTINUOUS OR CANTILEVER SPANS WITH THE FOLLOWING MINIMUM PROPERTIES:
 F_b = 2,400 PSI, F_v = 165 PSI, F_c = 650 PSI (PERPENDICULAR), E = 1,800,000 PSI.

ENGINEERED WOOD BEAMS AND I-JOIST

CONTRACTOR SHALL SUBMIT SHOP DRAWINGS AND SPECIFICATIONS FOR APPROVAL BY BUILDING OFFICIAL, DESIGN, FABRICATION AND ERECTION IN ACCORDANCE WITH THE LATEST ICC EVALUATION REPORT.

PARALLAM (PSL) BEAMS SHALL HAVE THE MINIMUM PORPPERTIES:
 F_b = 2,900 PSI, F_v = 290 PSI, F_c = 750 PSI (PERPENDICULAR), E = 2,000,000 PSI.
 MICROLLAM (LVL) BEAMS SHALL HAVE THE MINIMUM PORPPERTIES:
 F_b = 2,600 PSI, F_v = 285 PSI, F_c = 750 PSI (PERPENDICULAR), E = 1,900,000 PSI.

CALCULATION SHALL INCLUDE DEFLECTION AND CAMBER REQUIREMENTS. DEFLECTION SHALL BE LIMITED AS FOLLOWS:
 FLOOR LIVE LOAD MAXIMUM = L/480, FLOOR TOTAL LOAD MAXIMUM = L/240.

PREFABRICATED WOOD TRUSSES:

PREFABRICATED WOOD TRUSSES SHALL BE DESIGNED TO SUPPORT SELF WEIGHT PLUS LIVE LOAD AND SUPERIMPOSED DEAD LOADS AS STATED IN THE GENERAL NOTES TRUSSES SHALL BE DESIGNED & STAMPED BY A REGISTERED WASHINGTON STATE PROFESSIONAL ENGINEER AND FABRICATED FROM ONLY THOSE DESIGNS.

NONBEARING WALLS SHALL BE HELD AWAY FROM THE TRUSS BOTTOM CHORD WITH AN APPROVED FASTENER (SUCH AS SIMPSON STC) TO ENSURE THAT THE TRUSS BOTTOM CHORD WILL NOT BEAR ON THE WALL.

APPROVED HANGERS SHALL BE USED AT ALL CONNECTIONS OF RAFTERS, JACK OR HIP TRUSSES TO MAIN GIRDER TRUSS.

MANUFACTURER-DESIGNED AND APPROVED DIAGONAL AND SWAY BRACING SHALL BE INSTALLED AS REQUIRED.

ROOF/WALL SHEATHING

TYPICAL WALL SHEATHING SHALL BE 7/16" AND ROOF SHEATHING SHALL BE 7/16" UNLESS OTHERWISE SPECIFIED. MINIMUM NAILING SHALL BE 8d @ 6" O.C. @ PANEL EDGES AND 12" O.C. IN FIELD. U.N.O. ON SHEARWALL SCHEDULE. SPAN INDEX SHALL BE 24/0. PLYWOOD FLOOR SHEATHING SHALL BE 3/4" T&G SHEATHING, UNLESS OTHERWISE SPECIFIED. MINIMUM NAILING SHALL BE 8d COMMON OR 6d RING SHANK AT 6" O.C. @ PANEL EDGES AND 12" O.C. IN FIELD. SPAN INDEX SHALL BE 40/20. STAGGER END LAPS AT ROOF AND FLOOR SHEATHING. OSB SHEATHING PRODUCTS OF EQUIVALENT SPAN RATINGS SHALL BE ALLOWED.

SHEAR WALL SCHEDULE

| WALL MARK | SHEATHING TYPE | SIDES | SHEAR PANEL EDGE NAILING | FIELD NAILING | PANEL EDGES | BASE PLATE NAILING | ANCHOR BOLT DIA. & SPACING | SILL PLATE SIZE | HOLDOWN TYPES |
|-----------|----------------|-------|--------------------------|---------------|-------------|-------------------------------|----------------------------|-----------------|---------------|
| P1-6 | 7/16" | ONE | 8d @ 6" O.C. | 12" O.C. | 2X | 16d NAILS @ 12" O.C. | 5/8" @ 60" O.C. | 2X | PER PLAN |
| P1-4 | 7/16" | ONE | 8d @ 4" O.C. | 12" O.C. | 2-2X | 16d NAILS @ 4" O.C. | 5/8" @ 48" O.C. | 2X | PER PLAN |
| P1-3 | 7/16" | ONE | 8d @ 3" O.C. | 12" O.C. | 2-2X | 16d NAILS @ 3" O.C. | 5/8" @ 29" O.C. | 2-2X | PER PLAN |
| P2-3 | 7/16" | ONE | 8d @ 2" O.C. | 12" O.C. | 2-2X | 16d NAILS @ 2.3" O.C. STAGGER | 5/8" @ 20" O.C. | 2-2X | PER PLAN |

- FRAMING SHALL BE HEM-FIR #2 @ 16" O.C. MAX (U.N.O.). THICKNESS OF STUDS TO BE 2x UNLESS NOTED IN SCHEDULE.
- SHEATHING PANELS MAY BE LAYED VERTICAL OR HORIZONTAL. BLOCK ALL HORIZONTAL EDGES W/ 2x OR 3x BLOCKING PER SCHEDULE (U.N.O.)
- ALL EXTERIOR WALLS NOT DESIGNATED AS SHEARWALLS SHALL RECEIVE APA RATED SHEATHING OR ALL VENEER PLYWOOD SIDING OF EQUIVALENT THICKNESS AT POINT OF FASTENING ON PANEL EDGES. FULLY BLOCKED WITH MINIMUM NAILING OF 8d @ 6" O.C. EDGE, 12" O.C. FIELD.
- NAILING APPLIES TO ALL STUDS, TOP AND BOTTOM PLATES, AND BLOCKING. PLYWOOD JOINT AND SILL PLATE NAILING SHALL BE STAGGERED PER IBC TABLE 2306.3, NOTE (e).
- ANCHOR BOLT SPACING IS 6'-0" O.C. UNLESS NOTED OTHERWISE IN SCHEDULE. MINIMUM OF 2 ANCHOR BOLTS PER PIECE OF FOUNDATION PLATE. ANCHOR BOLTS SPACED NO GREATER THAN 12" AND NO LESS THAN 7 TIMES THE ANCHOR BOLT DIAMETER AT ENDS AND SPLICES. PROVIDE 1/2"x3"x3" WASHERS AT ANCHOR BOLTS. DO NOT RECESS BOLTS.
- ALL NAILS FOR SHEAR WALLS SHALL BE COMMON OR GALVANIZED BOX NAILS (U.N.O.) PER IBC TABLE 2306.3. ALL SPECIFIED NAILS SHALL HAVE THE FOLLOWING DIMENSIONS: 8d COMMON (0.131" DIA., 2 1/2" LONG), 8d BOX (0.113" DIA., 2 1/2" LONG), 10d COMMON (0.148" DIA., 3" LONG), 10d BOX (0.128" DIA., 3" LONG), 16d COMMON (0.162" DIA., 3 1/2" LONG), 16d SINKER (0.148" DIA., 3 1/2" LONG), 5d COOLER (0.089" DIA., 1 1/2" LONG), 6d COOLER (0.092" DIA., 1 7/8" LONG)
- 1 1/2" No. 6 DRYWALL SCREWS (TYPE W OR S) MAY BE SUBSTITUTED FOR NAILS LISTED AS 5d COOLER OR 6d COOLER FOR GYPSUM WALL BOARD SHEARWALLS PER IBC TABLE 2306.7.
- IN LIEU OF 3x VERTICALS AND BLOCKING AT PANEL EDGES, 2x2's W/ 10d FACE NAILS STAGGERED AT THE SAME SPACING AS PANEL EDGE NAILING MAY BE SUBSTITUTED. PLYWOOD EDGES TO BE CENTERED BETWEEN THE 2x2 MEMBERS (THIS ALTERNATIVE DOES NOT APPLY TO WALLS WITH 8d EDGE NAILING AT 2" O.C. OR 10d EDGE NAILING AT 3" OR 2" O.C. OR WALLS SHEATHED ON BOTH SIDES)
- HOLDDOWNS AND STRAPS OF EQUIVALENT UPLIFT CAPACITY MAY BE SUBSTITUTED FOR THOSE LISTED IN THE SHEARWALL SCHEDULE. COORDINATE WITH MANUFACTURER TO VERIFY APPLICABILITY AND PROPER INSTALLATION METHODS OF SUBSTITUTED HARDWARE.
- SQUASH BLOCKS REQUIRED AT ENDS OF SHEAR WALLS WHERE FULL BEARING IS NOT PROVIDED BY THE FRAMING BELOW.
- SIMPSON MASP MUDSILL ANCHORS, EVENLY SPACED, MAY BE SUBSTITUTED (2) FOR (1) FOR THE 3/8" DIA. SILL PLATE ANCHOR BOLTS SPECIFIED, (I.E. (2) MASP REPLACE (1) 3/8" DIA ANCHOR BOLT)

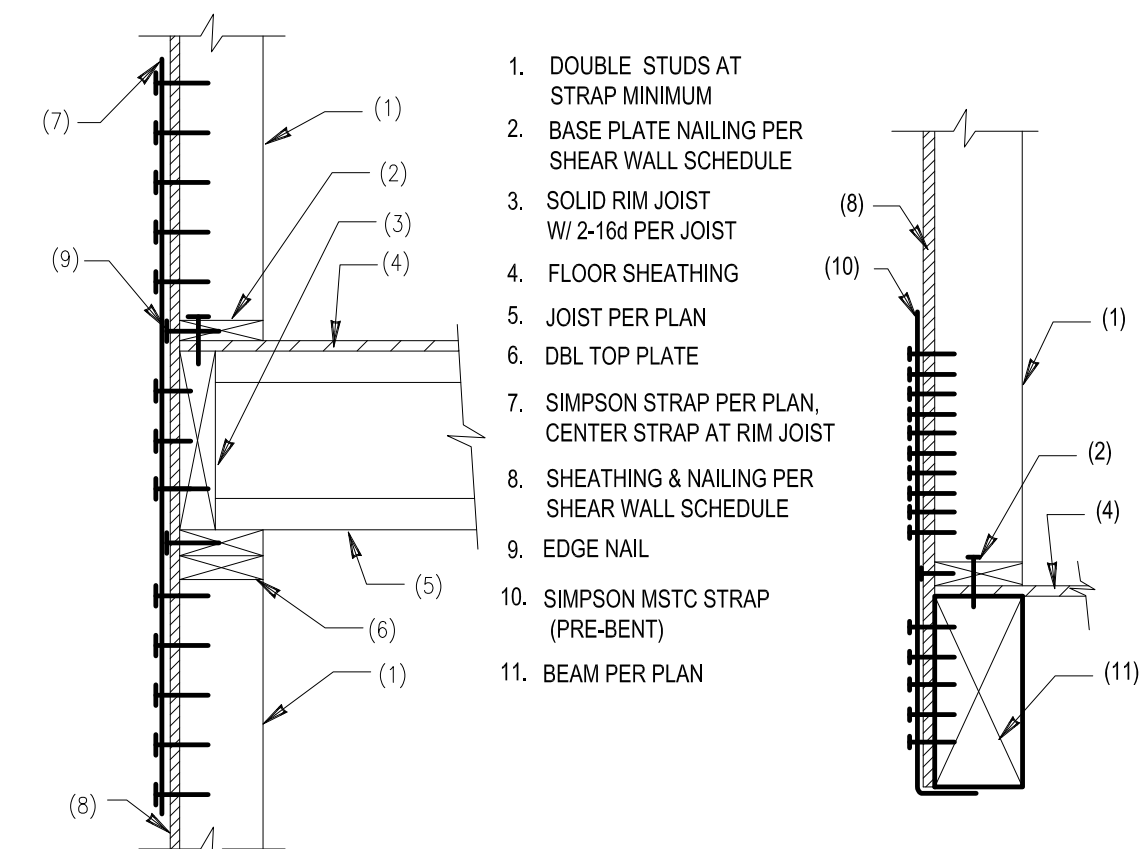

H1 N.T.S.
 TYPICAL SIMPSON STRAP WALL TO WALL AND WALL TO BEAM HOLDOWN

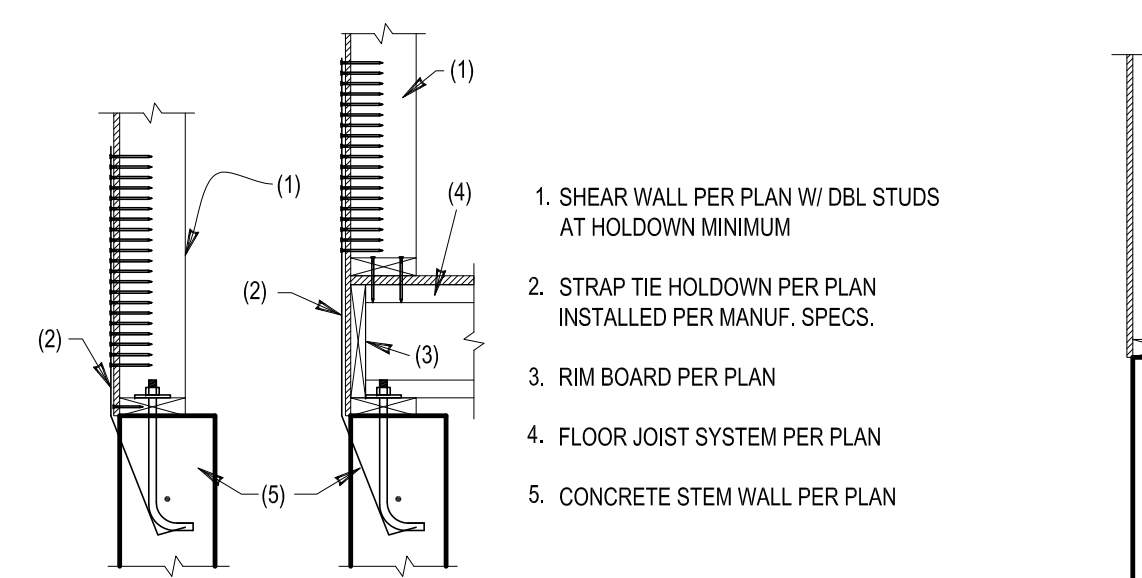

H2 N.T.S.
 TYPICAL STRAP TIE HOLDOWN @ FOUNDATION

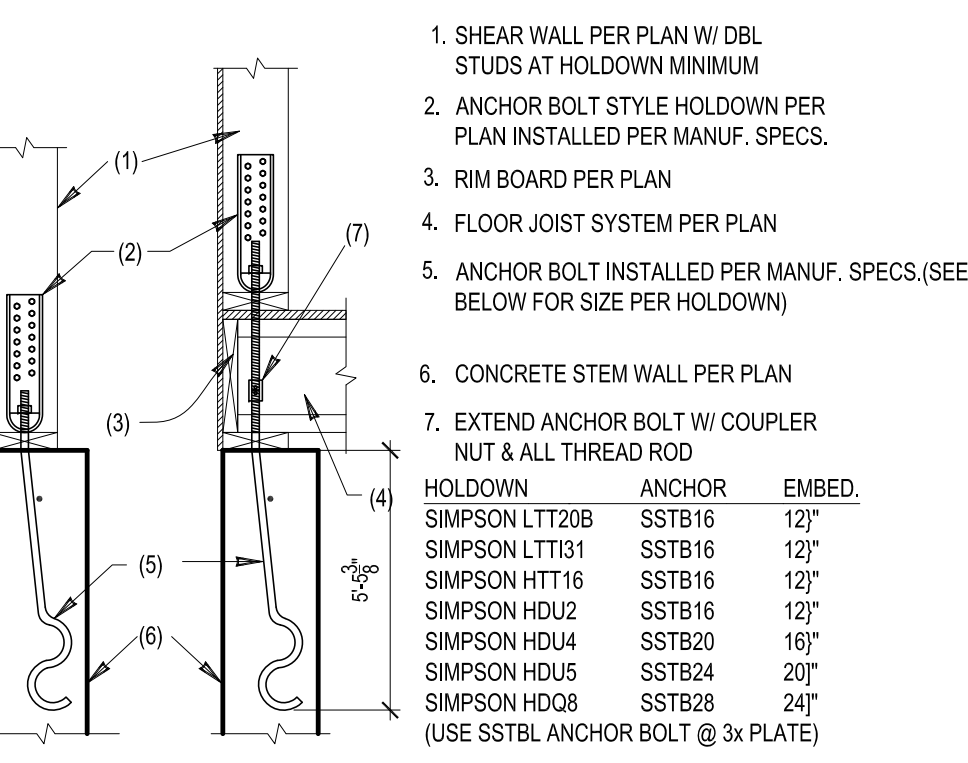

H3 N.T.S.
 TYPICAL ANCHOR BOLT HOLDOWN

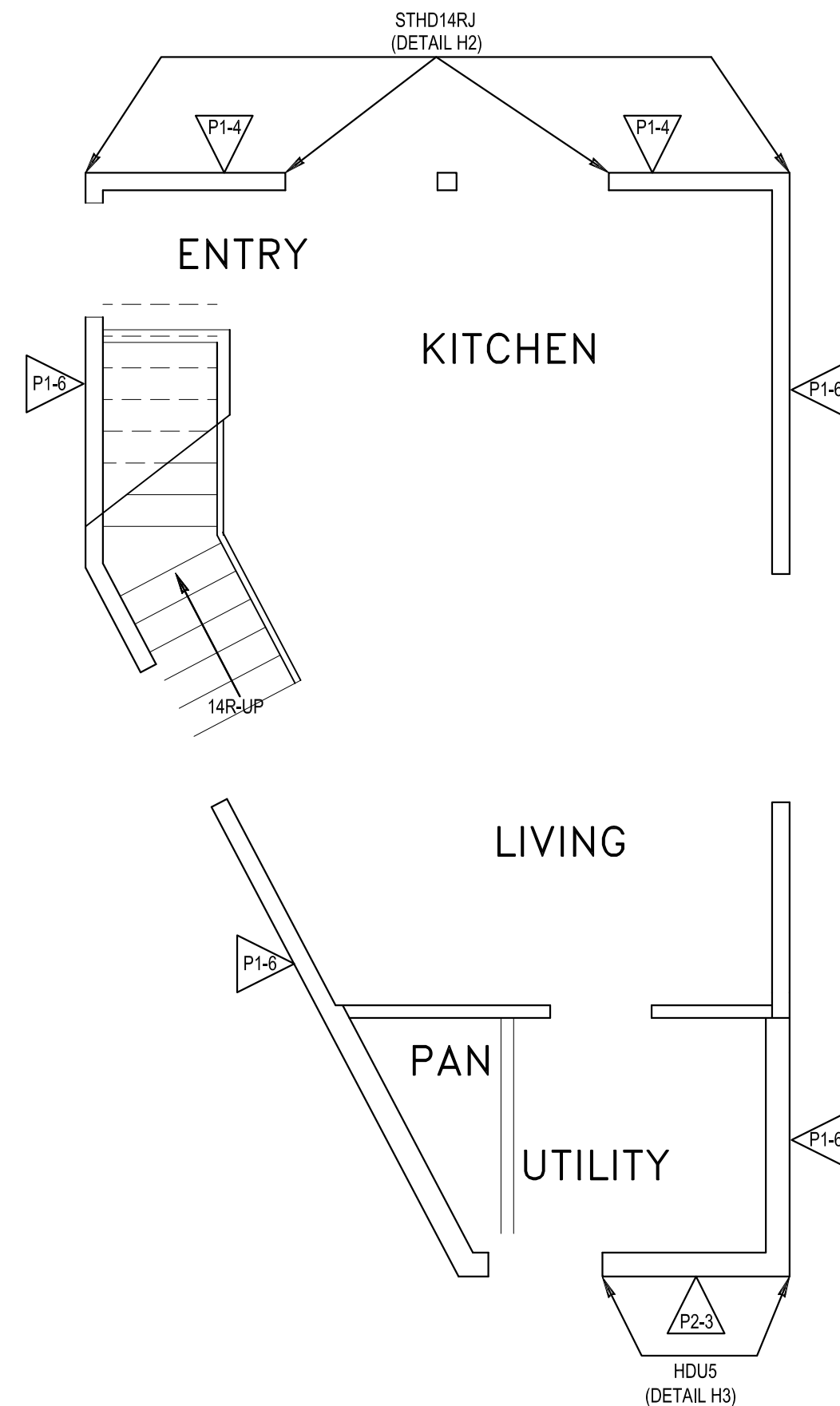

LOWER FLOOR KEY PLAN

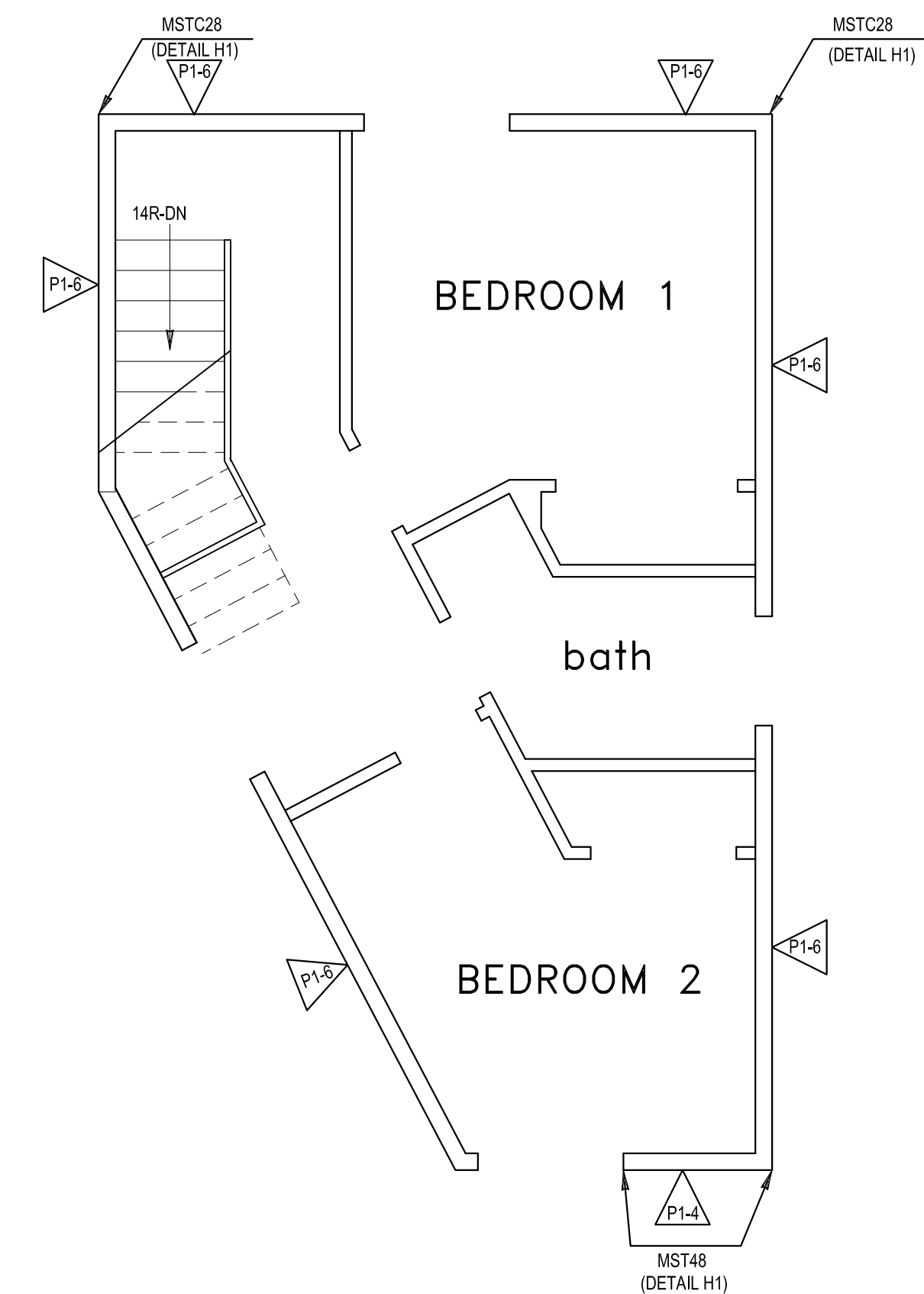

UPPER FLOOR KEY PLAN



NORTH

| DATE | REVISION | REV. BY: | |
|------------|----------|----------|-----------------|
| 10-19-2020 | REVISION | T.N. | INTAKE COMMENTS |
| | | | |
| | | | |

PREPARED BY:

URBALA, LLC
 DESIGNS * ENGINEERS * BUILDS
 33505 13th Place S, Suite A
 Federal Way, WA 98003
 Phone: 253-317-8773
 Web: www.urbaladevelopment.com, Ph. 253-835-1516

PREPARED FOR:

YOUN CHUNG RESIDENCE/ADU
NEW CONSTRUCTION
 7002 78th AVE. SE. MERCER ISLAND 98040
 PARCEL NUMBER: 252404-9217

BY: T.N.
 DATE: 07/25/20
 CHECKED: BT
 SHEET # **S1**
 PROJECT # **20-29E**

10/05/2020

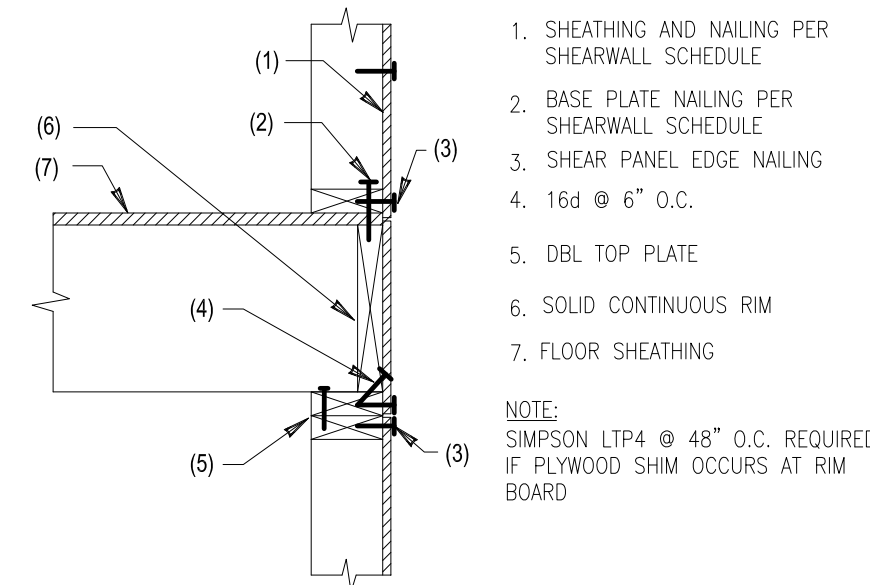

200 FLOOR JOIST AT STUD WALL
SCALE: N.T.S.

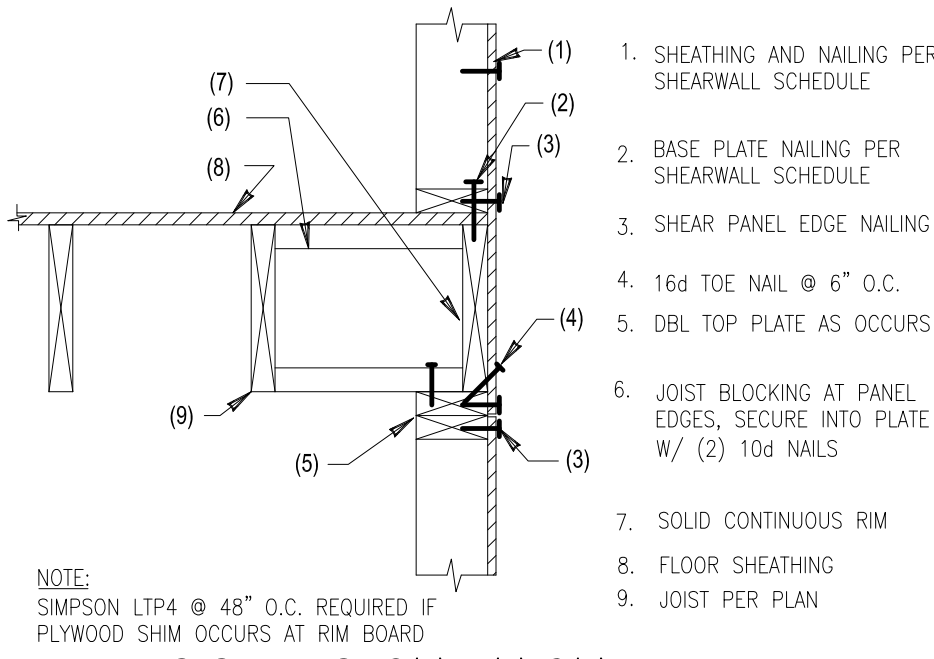

201 FLOOR JOIST AT STUD WALL
SCALE: N.T.S.

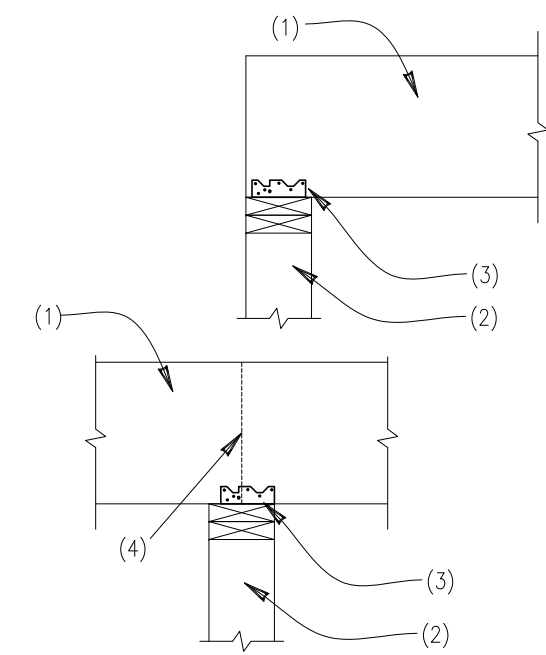

207 BEAM AT BEARING WALL
SCALE: N.T.S.

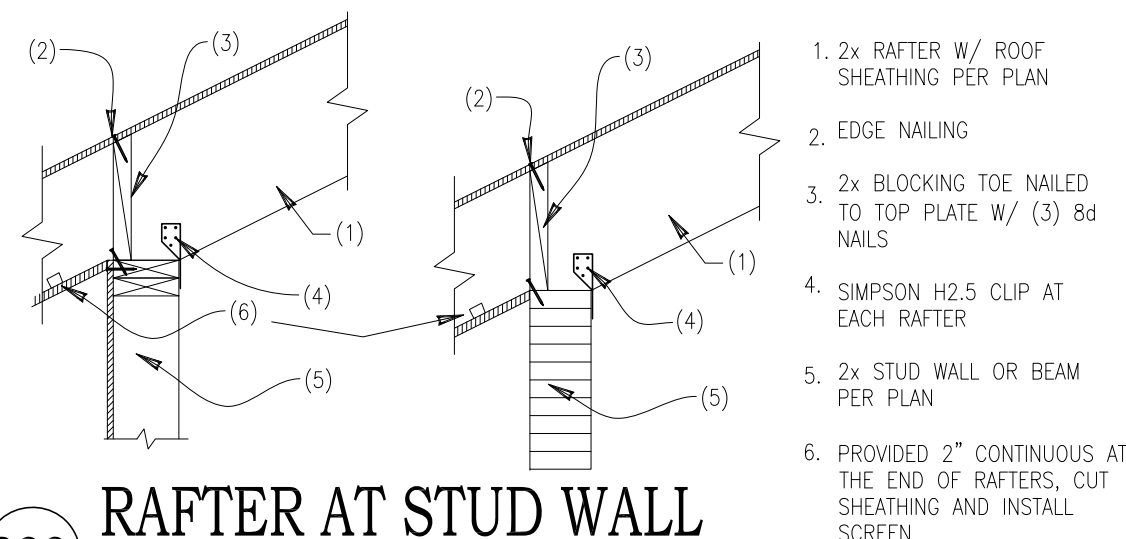

300 RAFTER AT STUD WALL
SCALE: N.T.S.

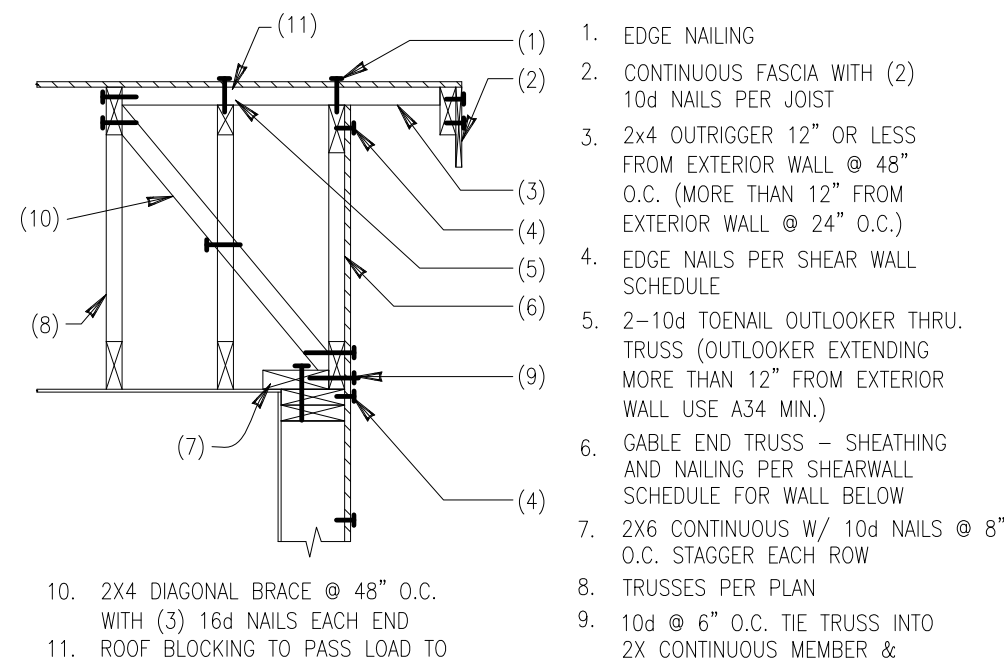

301 GABLE END TRUSS
SCALE: N.T.S.

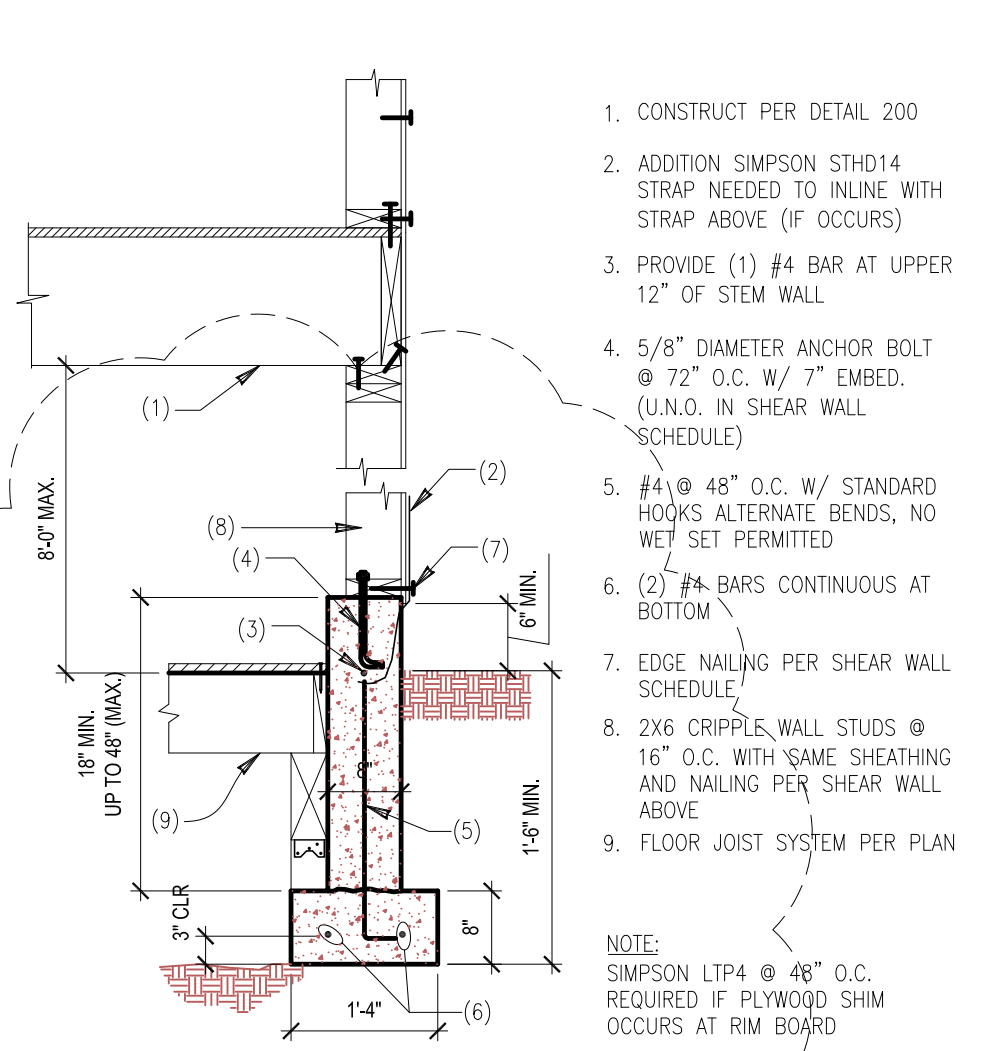

109 CRIPPLE WALL FOR SLOPED LOTS
SCALE: N.T.S.

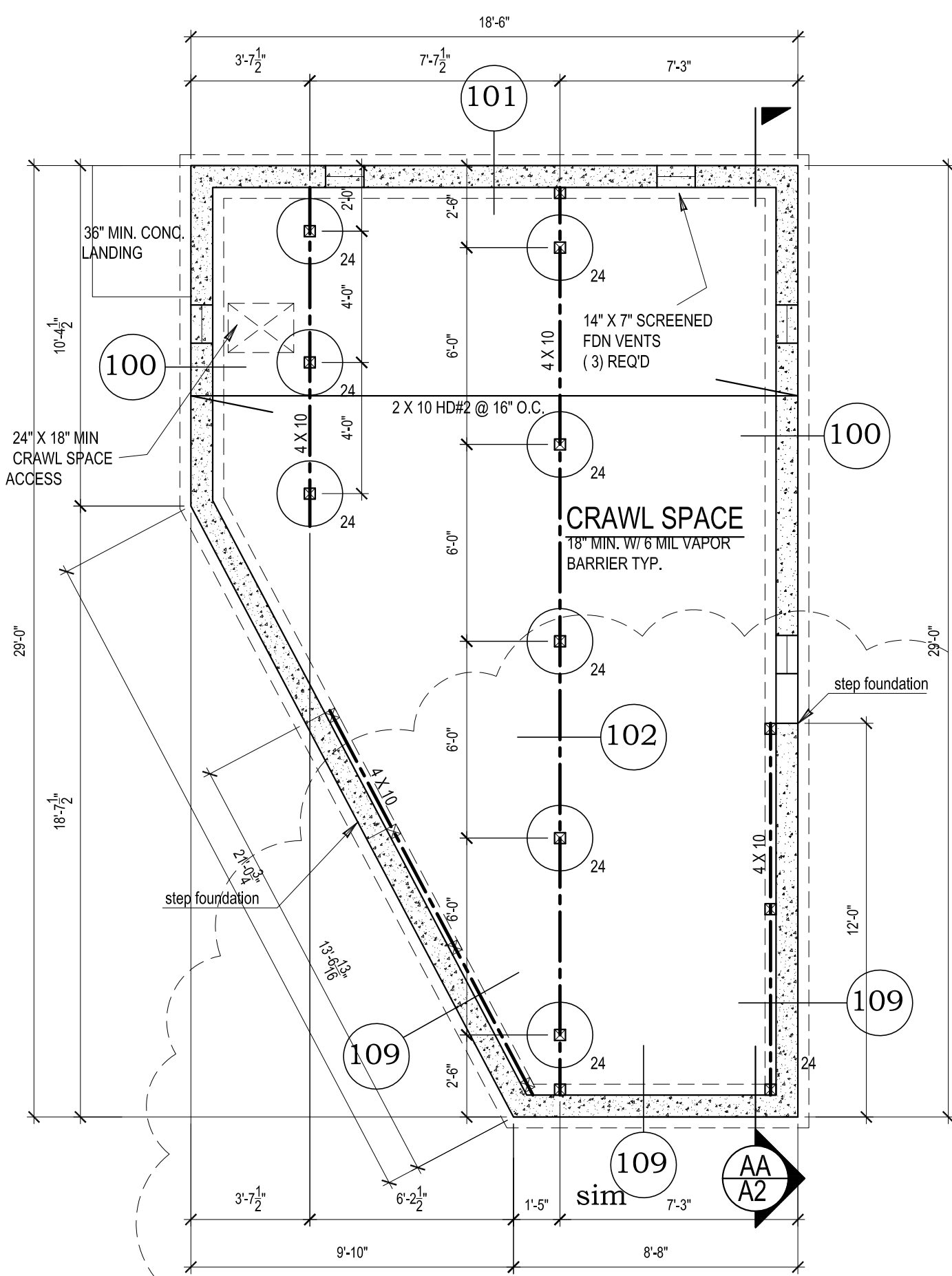

FOUNDATION PLAN
SCALE: 1/4" = 1'-0"

ROOF VENTS CAL.:
CONT. RIDGE VENT REQ'S:
- 445/300 = 1.84 SQ.FT.
CONT. RIDGE VENT APPLY:
1.84/(1.25'/12) = 14.24 LF

UPPER FLOOR FRAMING PLAN
SCALE: 1/4" = 1'-0"

- ALL DOOR/WINDOW HEADERS TO BE 6X8 DF#2 AT 2X6 BEARING WALLS, U.N.O.
- PROVIDE FIREBLOCKING AS REQUIRED PER I.R.C.
- WINDOW HEADERS AT 6'-8" ABOVE SUB FLOOR, U.N.O.
- EXTERIOR WALLS TO BE 2X6 AT 16" O.C., U.N.O.
- INTERIOR PARTITIONS TO BE 2X4 AT 16" O.C. (2X6 @ PLUMBING WALLS) U.N.O.
- PROVIDE SUPPLEMENTAL JOISTS/BLOCKING BELOW SHEAR WALLS AS INDICATED ON FRAMING PLAN
- PROVIDE SOLID FRAMING EQUAL TO THE WIDTH OF THE MEMBER BEING SUPPORTED (U.N.O.)
- FLOOR JOISTS AND BEAMS OF EQUAL OR BETTER CAPACITY MAY BE SUBSTITUTED FOR THOSE SHOWN ON THIS PLAN, "EQUAL" IS DEFINED AS HAVING MOMENT CAPACITY, SHEAR CAPACITY, AND STIFFNESS WITHIN 3% OF THE SPECIFIED JOISTS OR BEAMS.

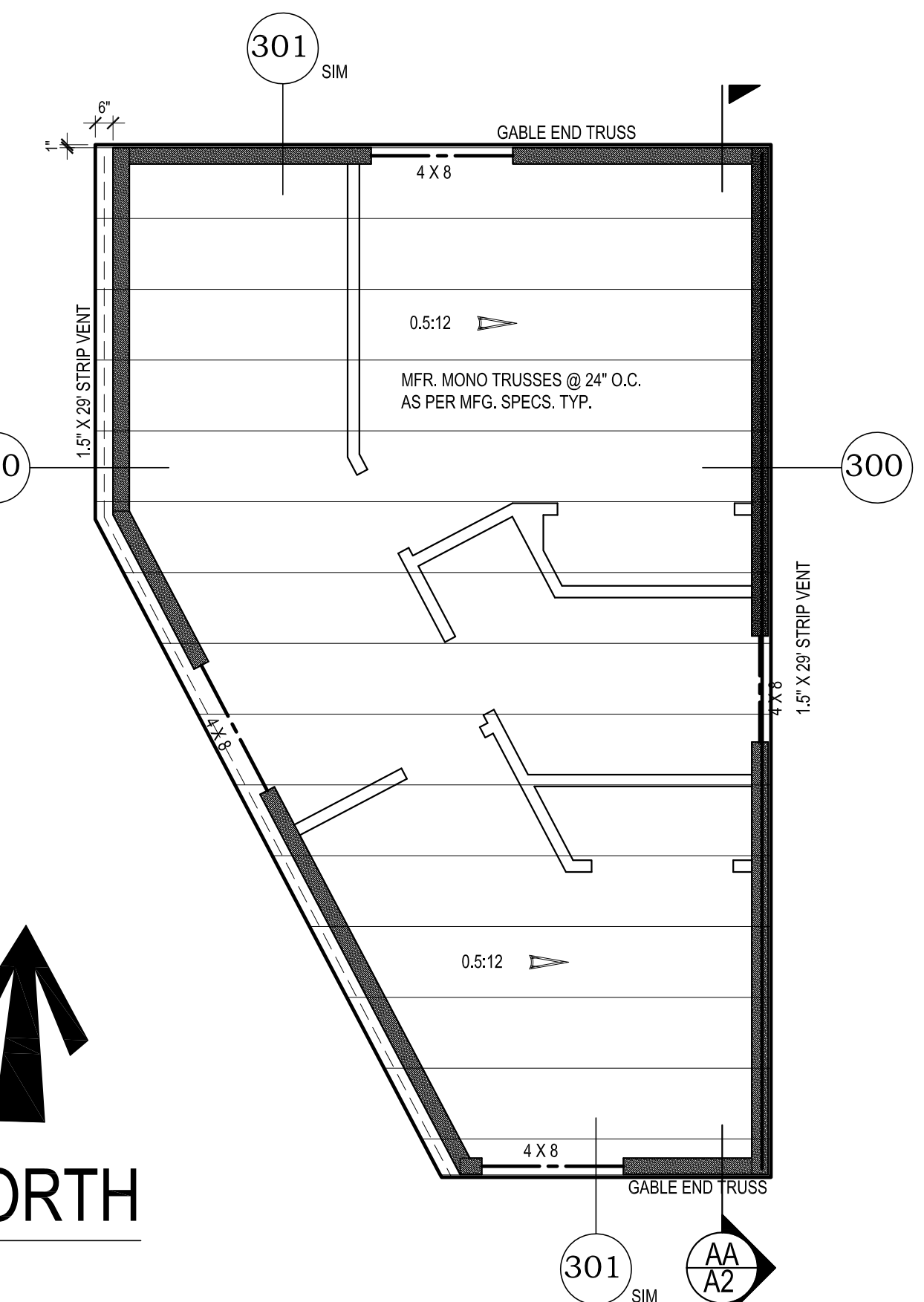

ROOF FRAMING PLAN
SCALE: 1/4" = 1'-0"

- ALL BEAMS AND HEADERS TO BE 6X8 DF #2 AT BEARING WALLS, U.N.O.
- SHADED AREAS INDICATE OVERFRAMING, 2X6 @ 24" O.C., U.N.O.
- BEARING WALLS ARE INDICATED AS SHADED WALLS
- PROVIDE VENTED BLOCKING AT REQUIRED TRUSS/RAFTER BAYS
- ALL MANUFACTURED TRUSSES:
 - * SHALL NOT BE FIELD ALTERED WITHOUT ENGINEER'S APPROVAL
 - * SHALL HAVE DESIGN DETAILS AND DRAWINGS ON SITE FOR FRAMING INSPECTION
 - * SHALL BE INSTALLED AND BRACED TO MANUFACTURER'S SPECIFICATION
 - * SHALL CARRY MANUFACTURER'S STAMP ON EACH TRUSS
- IF AN ENGINEERED ROOF FRAMING LAYOUT IS PROVIDED BY THE TRUSS SUPPLIER, THAT TRUSS LAYOUT SHALL SUPERCEDE THE TRUSS LAYOUT INDICATED IN THE PLANS. PROVIDE TRUSS LAYOUT AND SPECS ON SITE FOR INSPECTION.
- PROVIDE SOLID FRAMING EQUAL TO THE WIDTH OF THE MEMBER BEING SUPPORTED (U.N.O.)

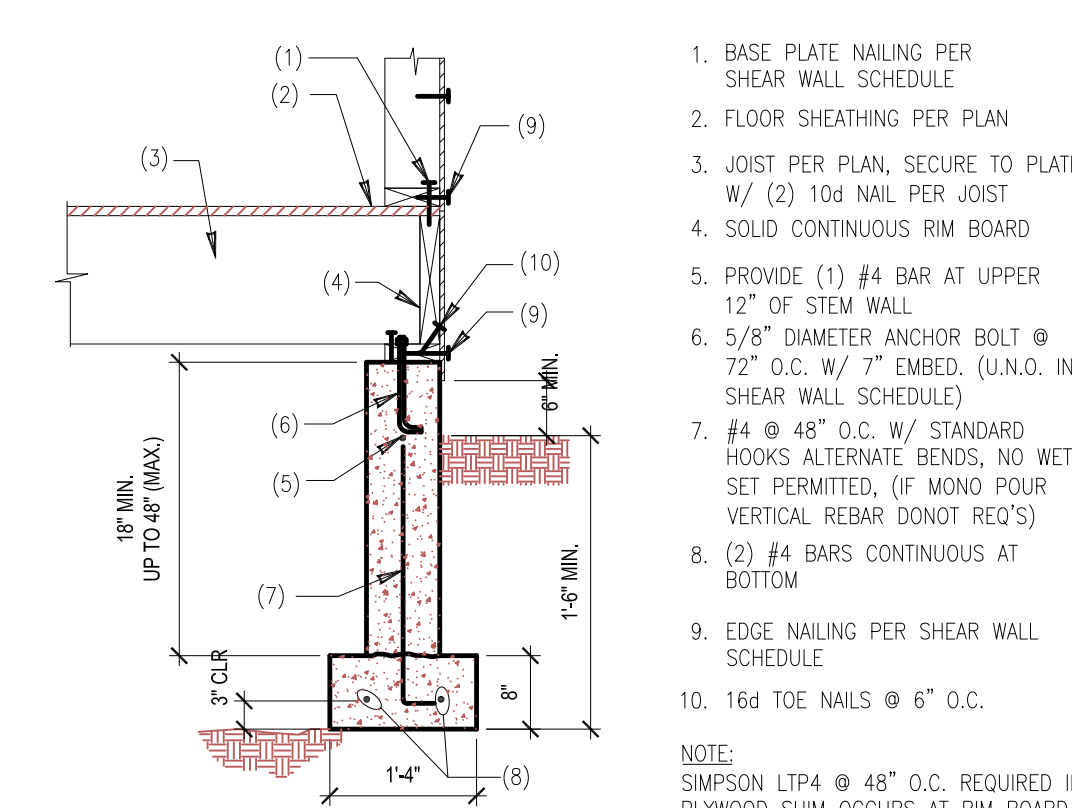

100 CRAWL SPACE FOUNDATION.
SCALE: N.T.S.

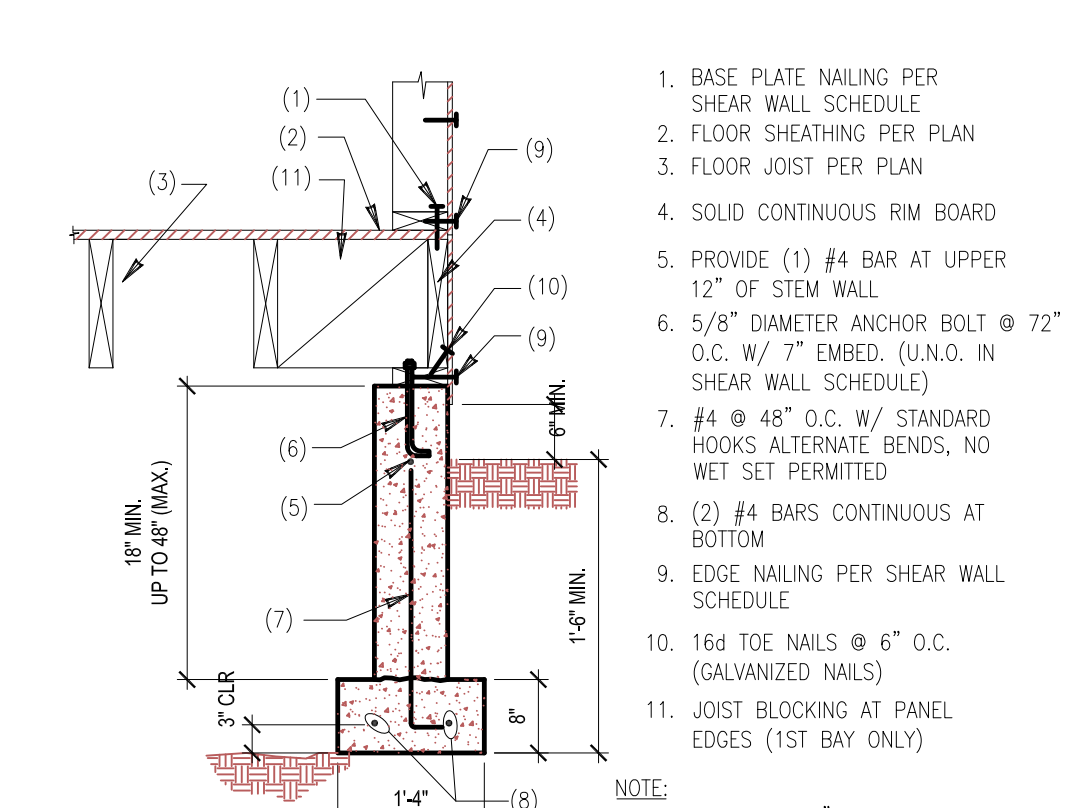

101 CRAWL SPACE FOUNDATION.
SCALE: N.T.S.

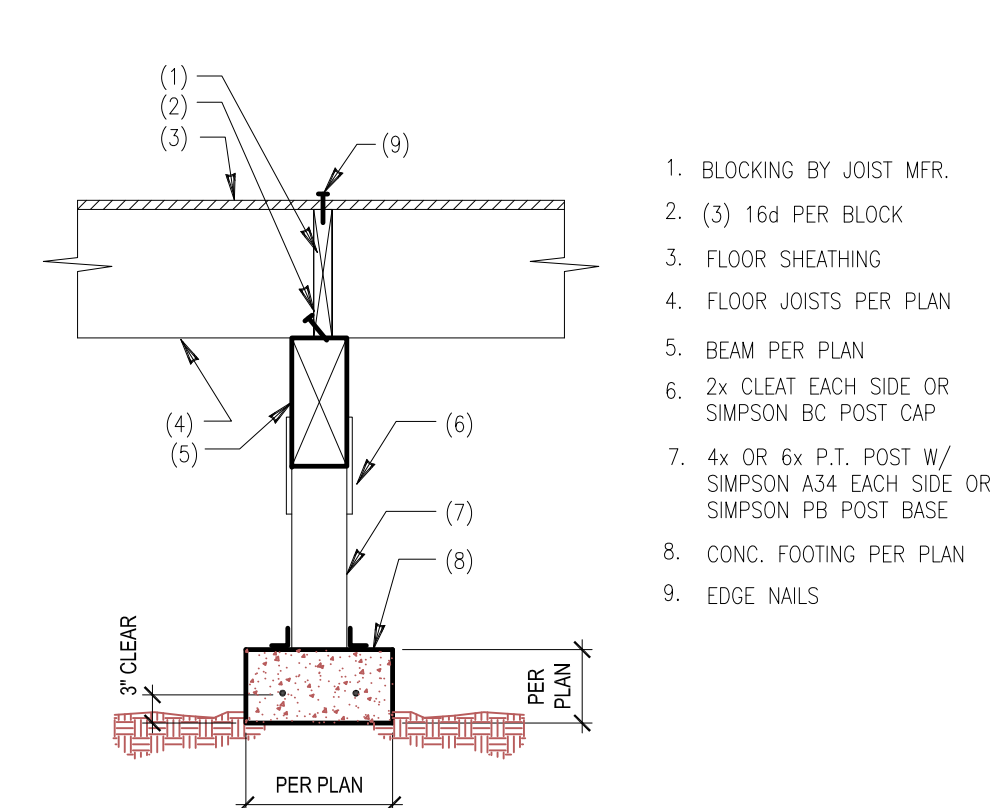

102 TYPICAL INTERIOR SPREAD FOOTING
SCALE: N.T.S.

NOTE:
CONTRACTOR TO VERIFY ALL DIMENSIONS AND CONDITIONS OF PROJECT AND REPORT ANY OMISSIONS / DISCREPANCIES TO DESIGNER PRIOR TO COMMENCING WORK. DESIGNER SHALL NOT BE RESPONSIBLE FOR DISCREPANT CONDITIONS RESULTING FROM UNAUTHORIZED WORK PERFORMED BY THE CONTRACTOR.

| FOUNDATION VENTILATION | |
|---|------------------------------------|
| USE 14" x 7" SCREENED FDN. VENTS (1) VENT = .52 SQ. FT. NET FREE VENT AREA | |
| $\frac{FDN. AREA}{300}$ | NET VENT AREA REQ'D (N.V.A.) |
| $\frac{N.V.A.}{.52}$ | QTY. OF VENTS REQUIRED |
| $\frac{444}{300} = 1.48$ | $\frac{1.48}{.52} = 2$ VENTS REQ'D |
| (2 VENTS REQUIRED) | |

| FOUNDATION FOOTING SCHEDULE | |
|---|--|
| NOTE: USE MIN. 6" WIDE POST BELOW BEAM SPLICES USE P.T. 4 X 4 POSTS BELOW 4 X BEAMS U.N.O. USE P.T. 6 X 6 POSTS BELOW 6 X BEAMS U.N.O. | |
| 24 | P.T. POST ON 24" DIA. X 10" THICK CONC. FOOTING |
| 24 | P.T. POST ON 24" DIA. X 10" THICK CONC. FOOTING W/ (3) #4 BARS EACH WAY |
| 30 | P.T. POST ON 30" X 30" X 12" THICK CONC. FOOTING W/ (3) #5 BARS EACH WAY |
| 36 | P.T. POST ON 36" X 36" X 12" THICK CONC. FOOTING W/ (4) #5 BARS EACH WAY |
| 42 | P.T. POST ON 42" X 42" X 12" THICK CONC. FOOTING W/ (4) #5 BARS EACH WAY |
| 48 | P.T. POST ON 48" X 48" X 12" THICK CONC. FOOTING W/ (5) #5 BARS EACH WAY |
| FOOTING SIZES BASED ON 1500 psf SOIL BEARING CAPACITY | |

| DATE | REVISION | REV. BY: | |
|------------|----------|----------|-----------------|
| 10-19-2020 | REVISION | T.N. | INTAKE COMMENTS |
| | | | |
| | | | |

PREPARED BY:

URBALA, LLC
DESIGNS • ENGINEERS • BUILDS
33505 13th Place S, Suite A
Federal Way, WA 98003
Phone: 253-517-8773
Web: www.urbandevelopment.com, Ph. 253-835-1516

PREPARED FOR:

YOUNG CHUNG RESIDENCE/ADU
NEW CONSTRUCTION
7002 78th AVE. SE. MERCER ISLAND 98040
PARCEL NUMBER: 252404-9217

BY: T.N.
DATE: 07/25/20
CHECKED: BT
SHEET # **S2**
2

PROJECT # **20-29E**

04/02/2021